

TECHNICAL MANUAL

**ORGANIZATION, DIRECT SUPPORT, AND
GENERAL SUPPORT MAINTENANCE REPAIR
PARTS AND SPECIAL TOOLS LIST
(INCLUDING DEPOT MAINTENANCE REPAIR
PARTS AND SPECIAL TOOLS)**

FOR

**AMPLIFIER-MIXER AM-6704/TSC
(NSN 5895-01-083-0726)**

HEADQUARTERS, DEPARTMENT OF THE ARMY

16 DECEMBER 1982

TECHNICAL MANUAL }
 No. 11-5895-1090-24P }

HEADQUARTERS
 DEPARTMENT OF THE ARMY,
 WASHINGTON, DC, 16 December 1982

**ORGANIZATIONAL, DIRECT SUPPORT, AND GENERAL SUPPORT
 MAINTENANCE REPAIR PARTS AND SPECIAL TOOLS LIST
 (INCLUDING DEPOT MAINTENANCE REPAIR PARTS
 AND SPECIAL TOOLS
 FOR
 AMPLIFIER-MIXER AM-6704/TSC
 (NSN 5895-01-083-0726)**

REPORTING ERRORS AND RECOMMENDING IMPROVEMENTS.
 You can help improve this manual. If you find any mistakes or if you know of a way to improve the procedures, please let us know. Mail your letter, DA Form 2028 (Recommended Changes to Publications and Blank Forms), or DA Form 2028-2 located in the back of this manual direct to Commander, US Army Communications-Electronics Command and Fort Monmouth, ATTN: DRSEL-ME-MP, Fort Monmouth, NJ 07703.
 In either case, a reply will be furnished direct to you.

Table of Contents

	Page	Illus Figure
SECTION I. Introduction	1	
II. Repair Parts List	5	
Group 09 Amplifier-Mixer AM-6704/TSC	5	1
0901 SHF Combiner	11	2
090101 SHF Channel Assembly	15	3
0902 SHF Drive Assembly . 17.....	4	
0903 TWT Amplifier (No parts authorized)		
0904 Transient Supressor	19	5
0905 RF Low Power Alarm	21	6
0906 SHF Output	23	7
0907 Power Supply (No parts authorized)		
0908 Thermoelectric Power Monitor	25	8
SECTION III. Special Tools List (Not applicable)		
IV. National Stock Number and Part Number Index	27	

**SECTION I
INTRODUCTION**

1. Scope

This manual lists spares and repair parts; special tools; special test, measurement, and diagnostic equipment (TMDE), and other special support equipment required for performance of organizational, direct support, and general support maintenance of the AM-6704/TSC. It authorizes the requisitioning and issue of spares and repair parts as indicated by the source and maintenance codes.

2. General

This Repair Parts and Special Tools List is divided into the following sections: a. Section II. Repair Parts List. A list of spares and repair parts authorized for use in the performance of maintenance. The list also includes parts which must be removed for replacement of the authorized parts. Parts lists are composed of functional groups in numeric sequence, with the parts in each group listed in figure and item number sequence.

b. Section III. Special Tools List. Not applicable.

c. Section IV. National Stock Number and Part Number Index. A list, in National item identification number (NIIN) sequence, of all National stock numbers (NSN) appearing in the listings, followed by a list, in alphameric sequence, of all part numbers appearing in the listings. National stock numbers and part numbers are cross-referenced to each illustration figure and item number appearance.

3. Explanation of Columns

a. *Illustration.* This column is divided as follows:

(1) *Figure number.* Indicates the figure number of the illustration on which the item is shown.

(2) *Item number.* The number used to identify item called out in the illustration.

b. *Source, Maintenance, and Recoverability (SMR) Codes.*

(1) *Source code.* Source codes indicate the manner of acquiring support items for maintenance, repair, or overhaul of end items. Source codes are entered in the first and second positions of the Uniform SMR Code format as follows:

<i>Code</i>	<i>Definition</i>
-------------	-------------------

- | | |
|-----------|--|
| PA | Item procured and stocked for anticipated or known usage. |
| PB | Item procured and stocked for insurance purpose because essentiality dictates that a minimum quantity be available in the supply system. |
| PD | Support item, excluding support equipment, procured for initial issue or outfitting and stocked only for subsequent or additional initial issues or outfittings. Not subject to automatic replenishment. |
| MD | Item to be manufactured or fabricated at the depot maintenance level. |
| XA | Item is not procured or stocked because the requirements for the item will result in the replacement of the next higher assembly. |
| XB | Item is not procured or stocked. If not available through salvage, requisition. |
| XD | A support item that is not stocked. When required, item will be procured through normal supply channels. |

NOTE

Cannibalization or salvage may be used as a source of supply for any items source coded above except those coded XA and aircraft support items as restricted by AR 700-42.

(2) *Maintenance code.* Maintenance codes are assigned to indicate the levels of maintenance authorized to USE and REPAIR support items. The maintenance codes are entered in the third and fourth positions of the Uniform SMR Code format as follows:

(a) The maintenance code entered in the third position will indicate the lowest maintenance level authorized to remove, replace, and use the support item. The maintenance code entered in the third position will indicate one of the following levels of maintenance:

- | <i>Code</i> | <i>Application/Explanation</i> |
|-------------|--|
| O- | item is removed, replaced, used at the organizational level. |
| F- | item is removed, replaced, used at the direct support level. |

<i>Code</i>	<i>Application/Explanation</i>
H-	item is removed, replaced, used at the general support level.
D-	items that are removed, replaced, used at depot, mobile depot, specialized repair activity only.

(b) The maintenance code entered in the fourth position indicates whether the item is to be repaired and identifies the lowest maintenance level with the capability to perform complete repair (i.e., all authorized maintenance functions). This position will contain one of the following maintenance codes:

<i>Code</i>	<i>Application/Explanation</i>
F-	lowest maintenance level capable of complete repair of the support item is the direct support level.
H-	lowest maintenance level capable of complete repair of the support item is the general support level.
D-	lowest maintenance level capable of complete repair of the support item is the depot level.
Z-	No repair is authorized.

(3) Recoverability code. Recoverability codes are assigned to support items to indicate the disposition action on unserviceable items. The recoverability code is entered in the fifth position of the Uniform SMR Code format as follows: Recoverability codes Definition Z-Nonreparable item. When unserviceable, condemn and dispose at the level indicated in position 3.

- F-** Repairable item. When uneconomically repairable, condemn and dispose at the direct support level.
- H-** Repairable item. When uneconomically repairable, condemn and dispose at the general support level.
- D-** Repairable item. When beyond lower level repair capability, return to depot. Condemnation and disposal not authorized below depot level.
- L-** Repairable item. Repair, condemnation, and disposal not authorized below depot/specialized repair activity level.
- A-** Item requires special handling or condemnation procedures because of specific reasons (i.e., precious metal content, high dollar value, critical material or hazardous material). Refer to appropriate manuals/directives for specific instructions.

c. National Stock Number. Indicates the National stock number assigned to the item and will be used for requisitioning purposes.

d. Federal Supply Code for Manufacturer (FSCM). The FSCM is a 5-digit numeric code listed in SB 708-

41/42 which is used to identify the manufacturer, distributor, or Government agency, etc.

e. Part Number. Indicates the primary number used by the manufacturer (individual, company, firm, corporation, or Government activity), which controls the design and characteristics of the item by means of its engineering drawings, specifications, standards, and inspection requirements to identify an item or range of items.

NOTE

When a stock numbered item is requisitioned, the repair part received may have a different part number than the part being replaced.

f. Description. Indicates the Federal item name and, if required, a minimum description to identify the item.

g. Unit of Measure (U/M). Indicates the standard of the basic quantity of the listed item as used in performing the actual maintenance function. This measure is expressed by a two-character alphabetical abbreviation (e.g., ea, in, pr, etc). When the unit of measure differs from the unit of issue, the lowest unit of issue that will satisfy the required units of measure will be requisitioned.

h. Quantity Incorporated in Unit. Indicates the quantity of the item used in the breakout shown on the illustration figure, which is prepared for a functional group, subfunctional group, or an assembly.

4. Special Information

a. Detailed manufacturing instructions for items source coded to be manufactured or fabricated are found in TM 11-5895-1090-34.

b. The following publications pertain to the AM-6704/TSC and its components: TM 11-5895-1090-34, Amplifier-Mixer, AM-6704/TSC (To be published).

c. National stock numbers (NSN's) that are missing from P source coded items have been applied for and will be added to this TM by future change/revision when they are entered in the Army Master Data File (AMDF). Until the NSN's are established and published, submit exception requisitions to: Commander, US Army Communications-Electronics Command, and Fort Monmouth, ATTN: DRSEL-MM, Fort Monmouth, NJ 07703 for the part required to support your equipment.

5. How to Locate Repair Parts

a. When National stock number or part number is unknown.

(1) *First.* Using the table of contents, determine the functional group within which the item belongs. This is necessary since illustrations are prepared for functional groups and listings are divided into the same groups.

(2) *Second.* Find the illustration covering the functional group to which the item belongs.

(3) *Third.* Identify the item on the illustration and note the illustration figure and item number of the item.

(4) *Fourth.* Using the Repair Parts Listing, find the figure and item number noted on the illustration.

b. When National stock number or part number is known.

(1) *First.* Using the Index of National Stock Numbers and Part Numbers, find the pertinent National stock number or part number. This index is in NIIN sequence followed by a list of part numbers in alphameric sequence, cross-referenced to the illustration figure number and item number.

(2) *Second.* After finding the figure and item number, locate the figure and item number in the repair parts list.

6. Abbreviations

Not applicable.

(Next printed page is 4)

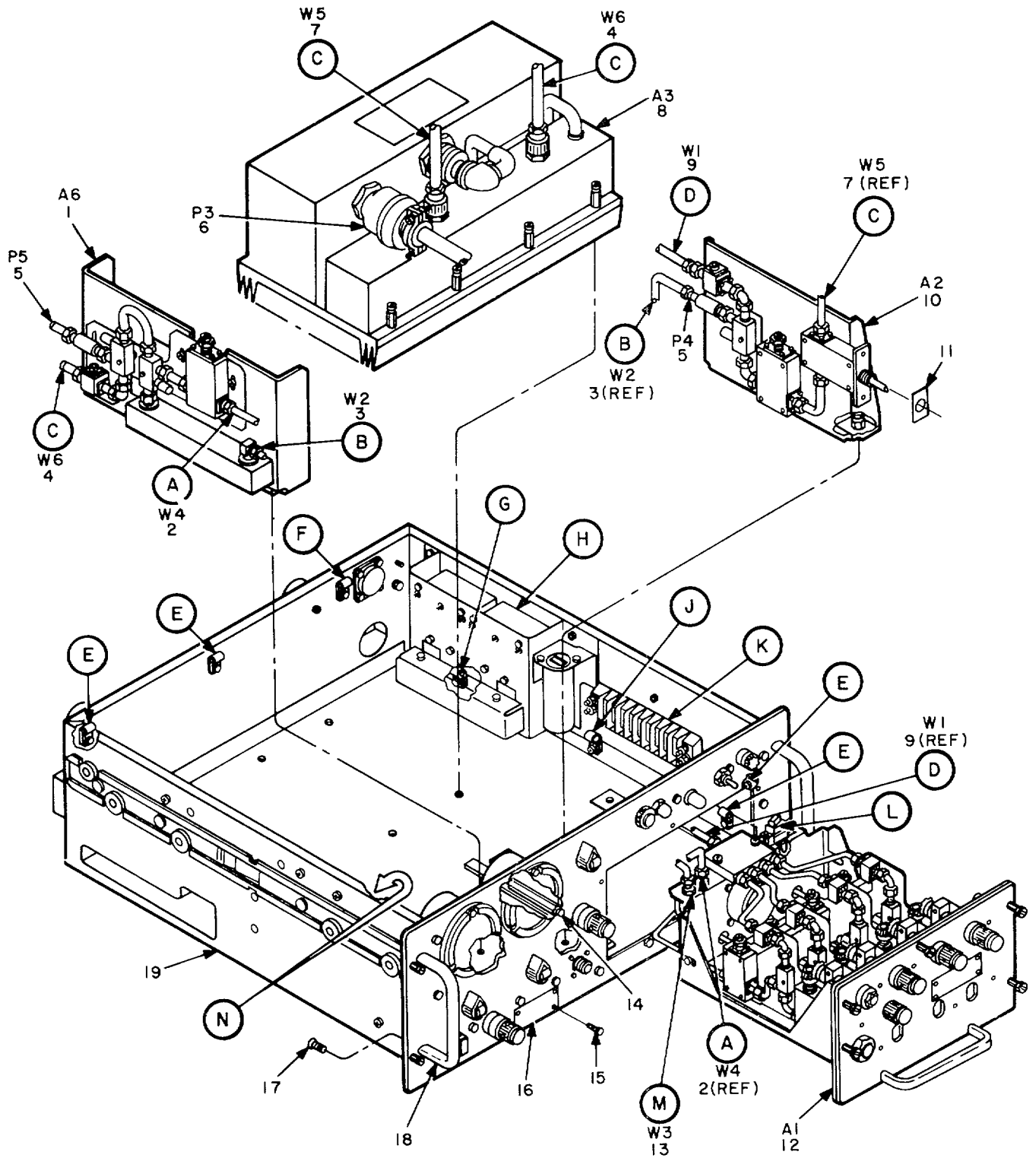

Figure 1. Amplifier-Mixer AM-6704/TSC (Sheet 1 of 9).

EL60W001

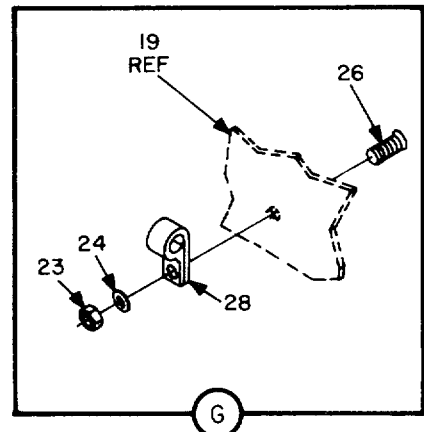
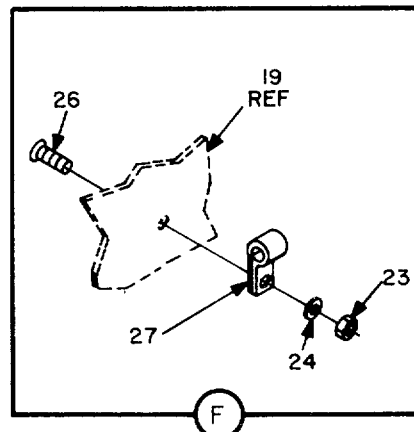
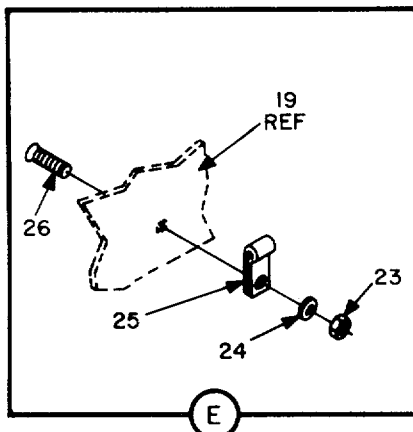
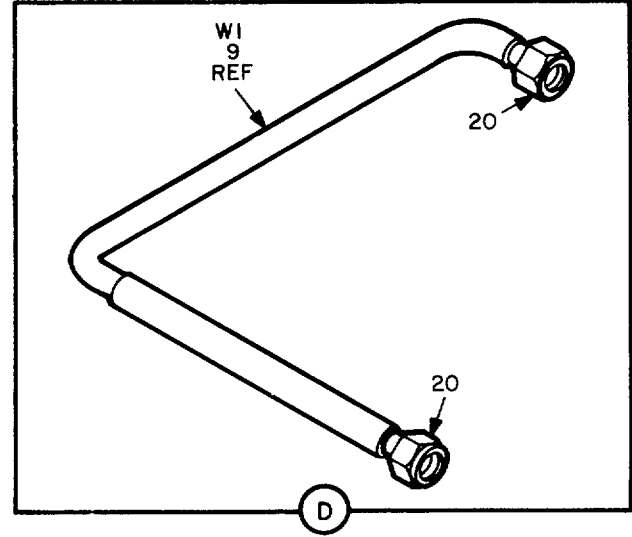
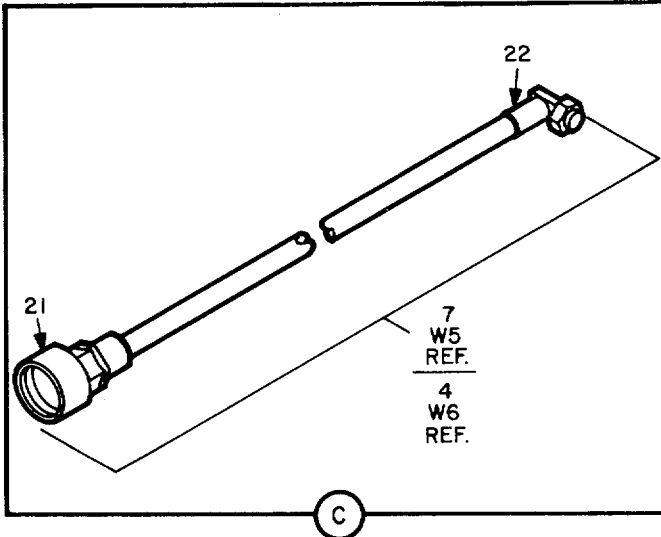
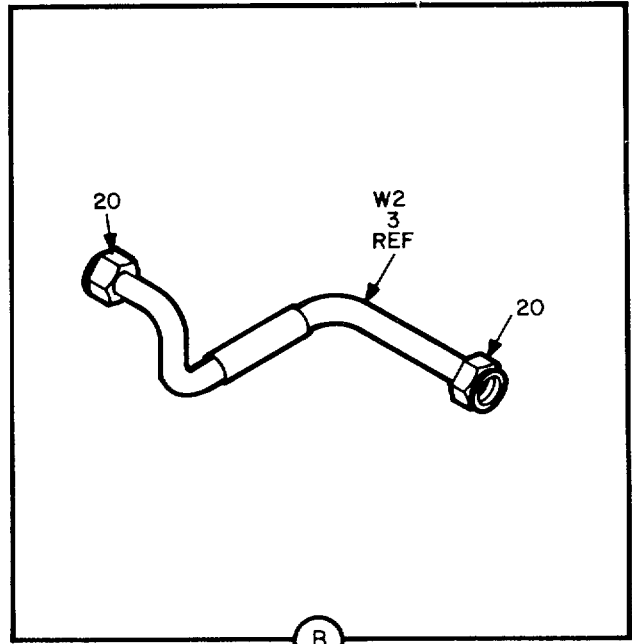
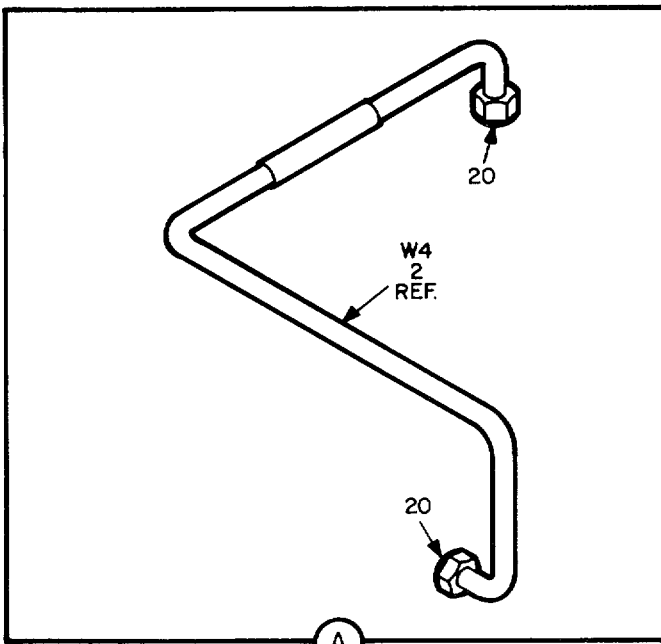
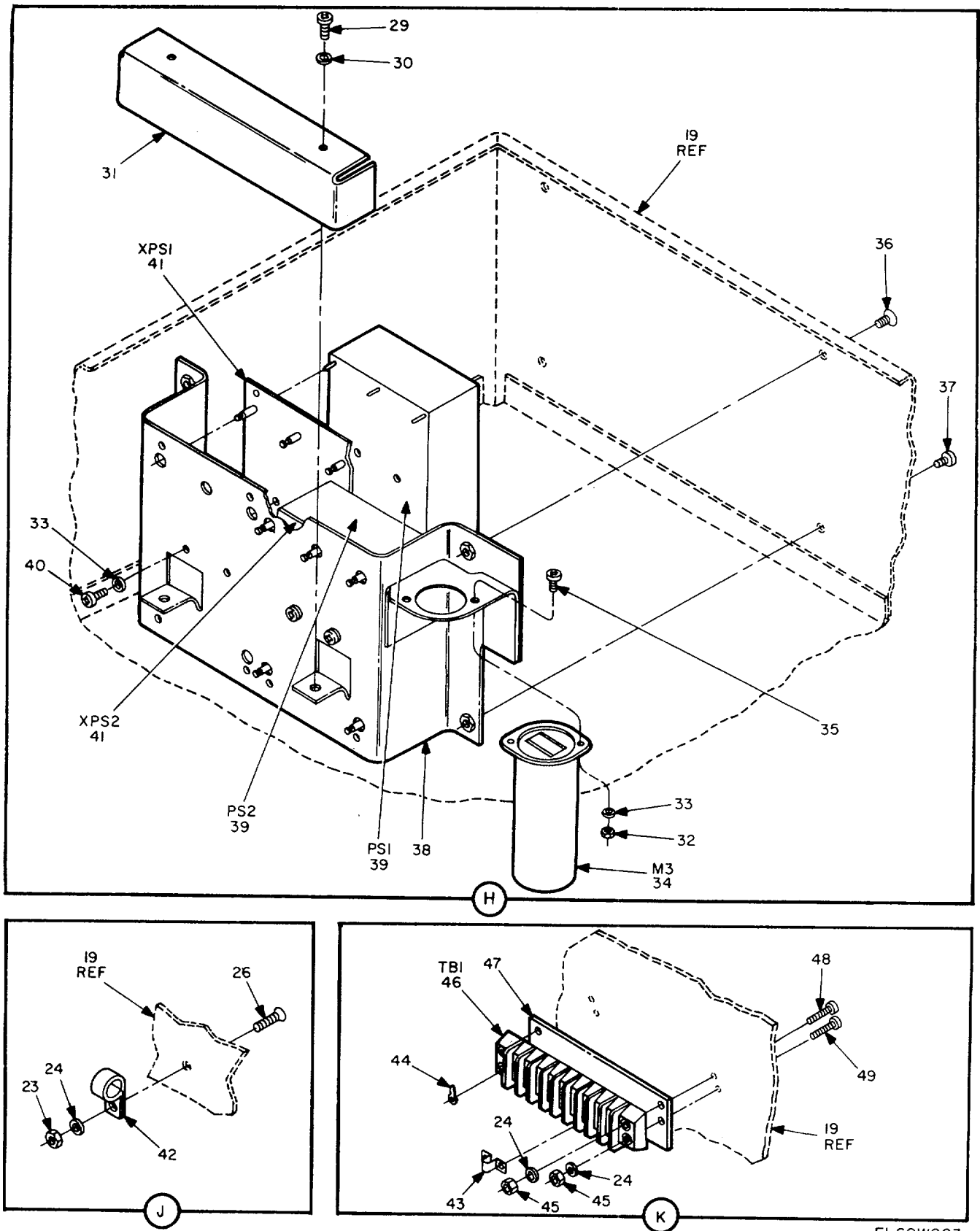

Figure 1. Amplifier-Mixer AM-6704/TSC (Sheet 2 of 9).

EL60W002



EL60W003

Figure 1. Amplifier-Mixer AM-6704/TSC (Sheet 3 of 9).

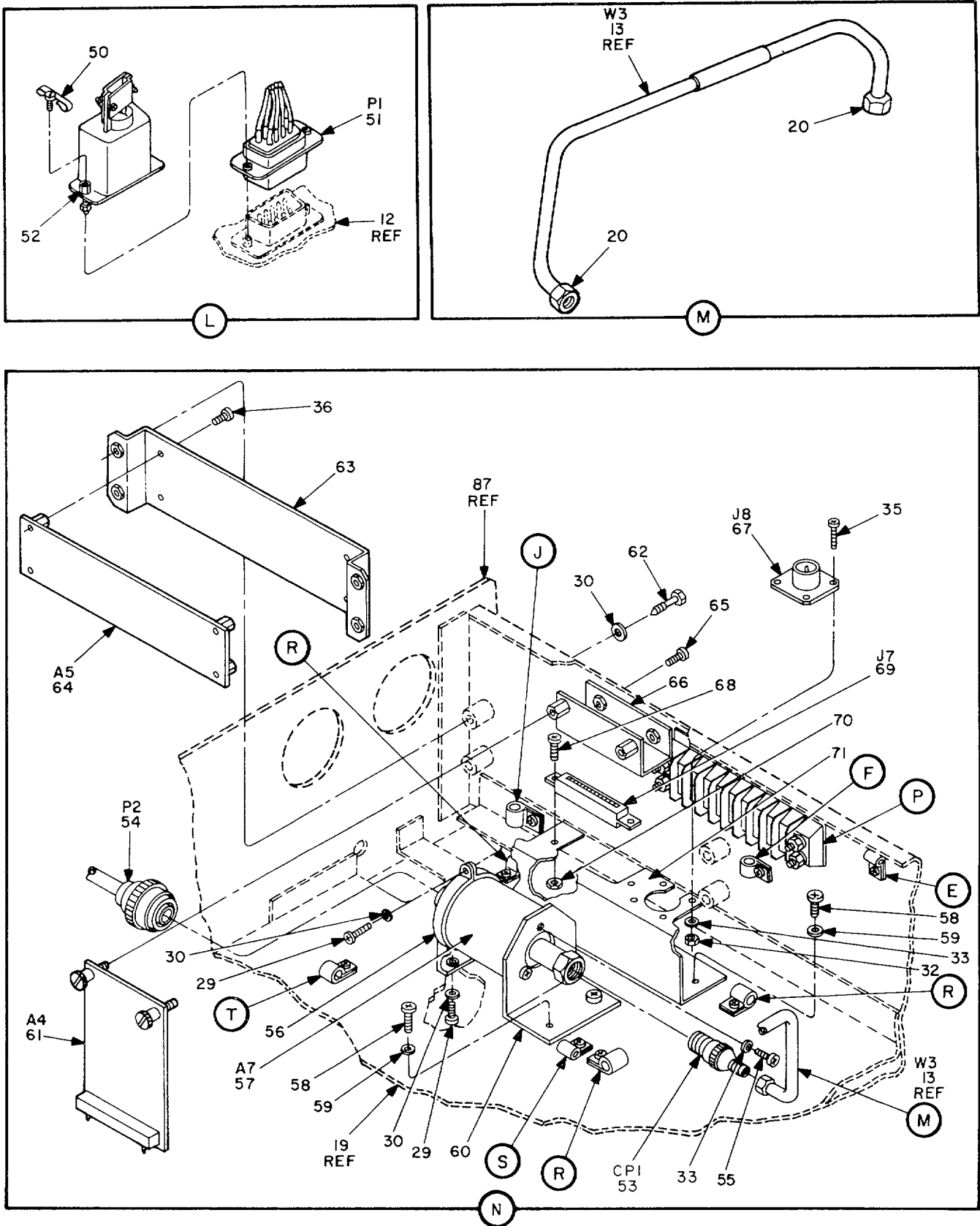

Figure 1. Amplifier-Mixer AM-6704/TSC (Sheet 4 of 9).

EL60W004

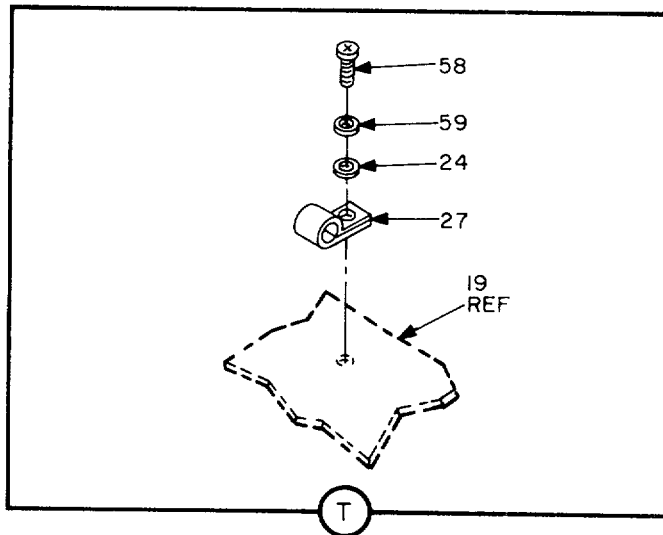
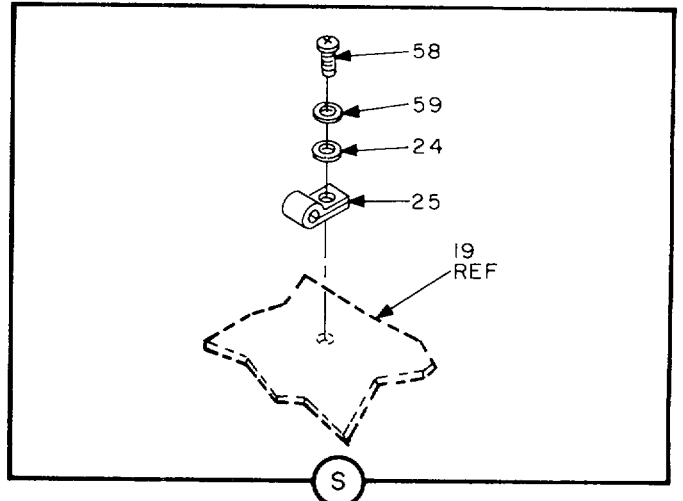
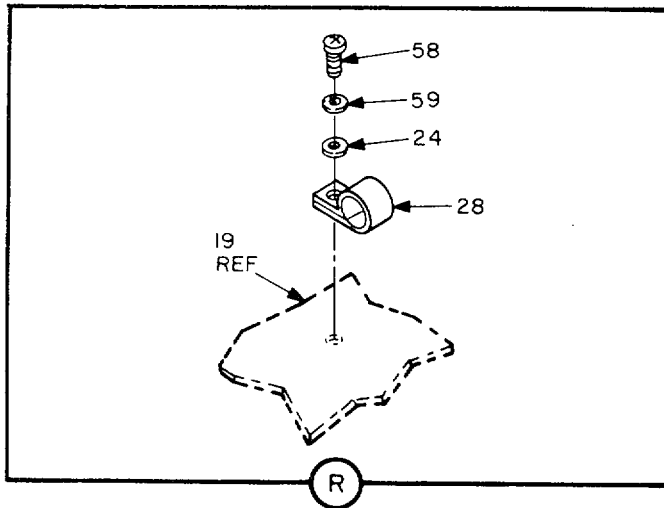
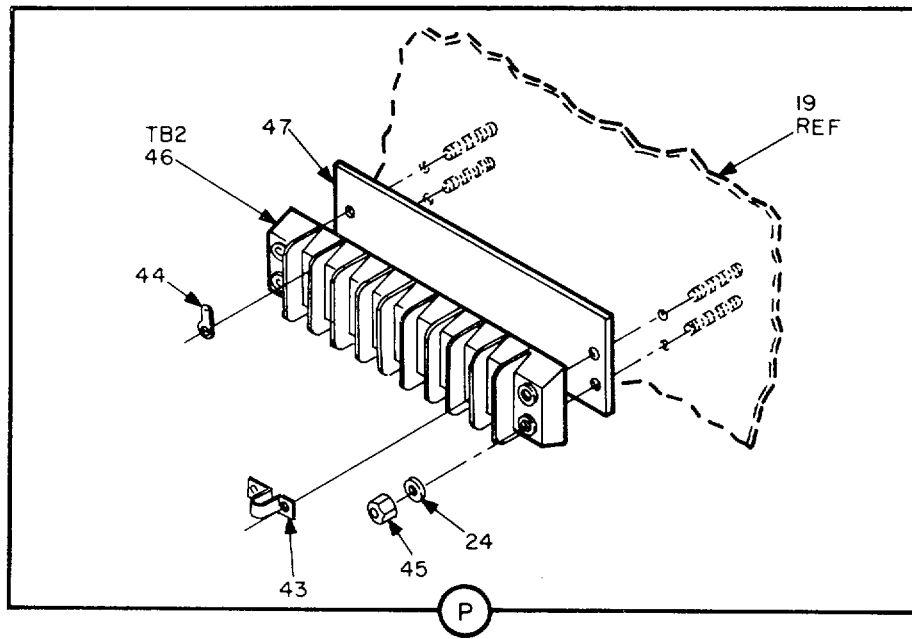

Figure 1. Amplifier-Mixer AM-6704/TSC (Sheet 5 of 9).

EL60W005

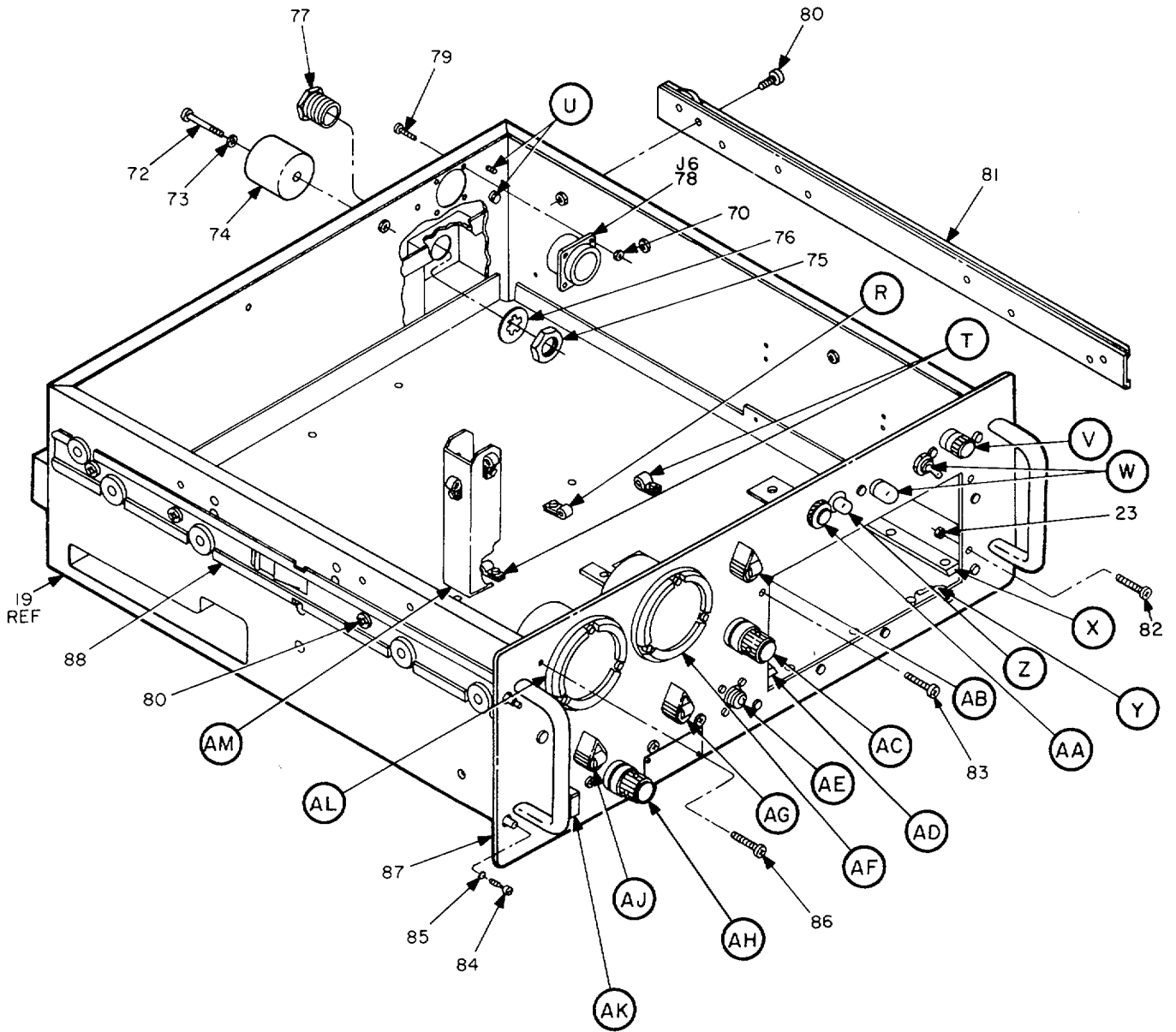

Figure 1. Amplifier-Mixer AM-6704/TSC (Sheet 6 of 9).

EL60W006

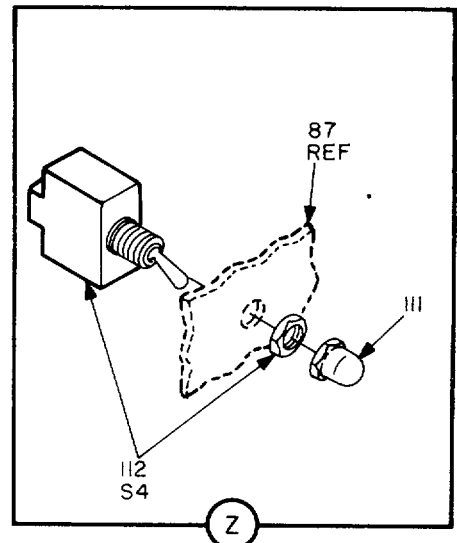
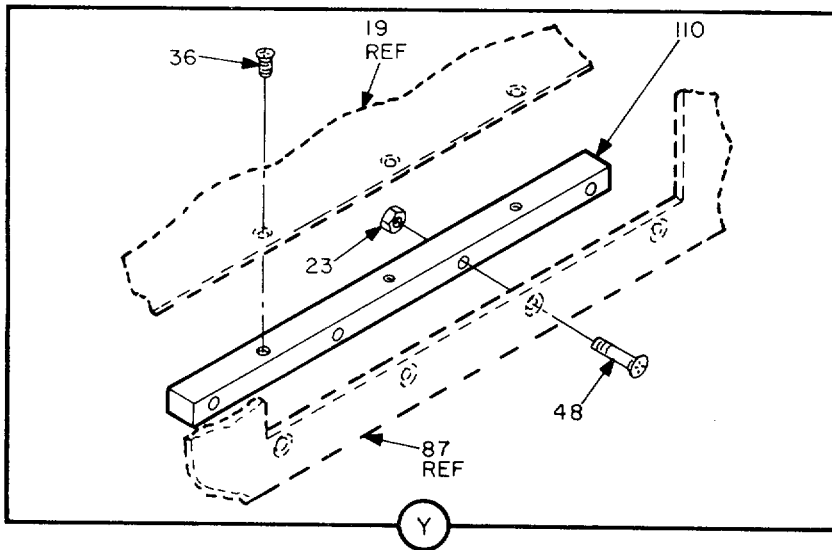
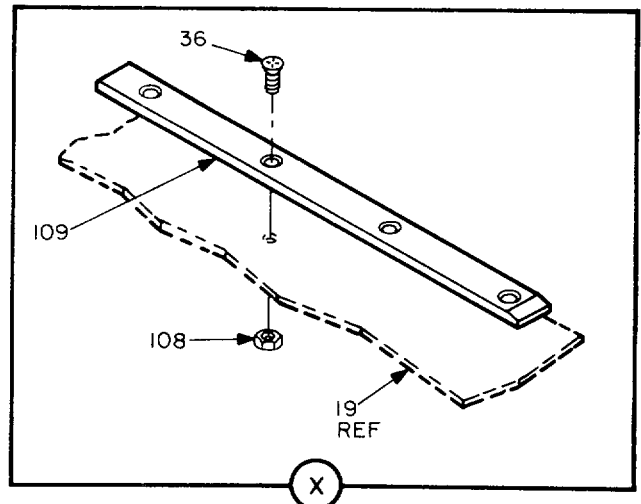
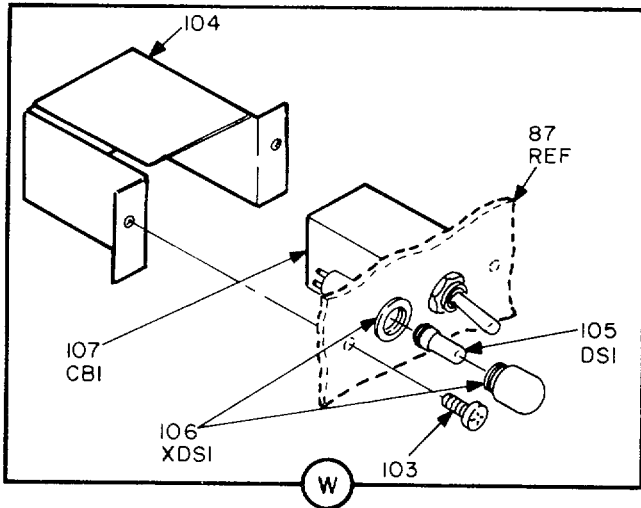
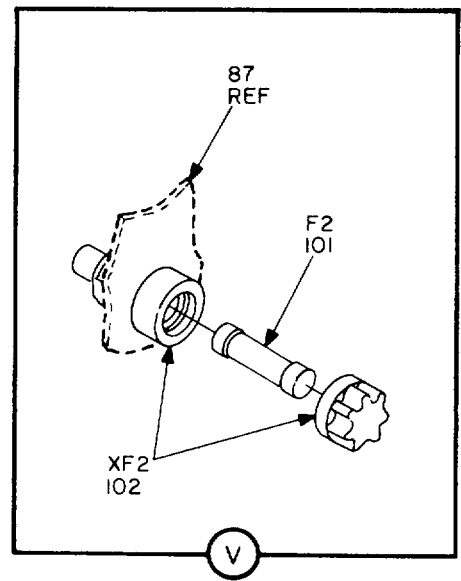
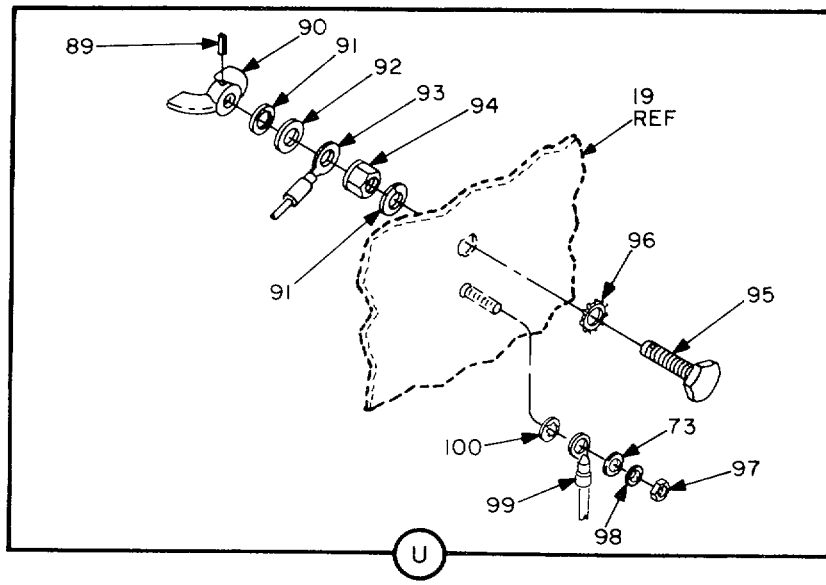

Figure 1. Amplifier-Mixer 6704/TSC (Sheet 7 of 9).

EL60W007

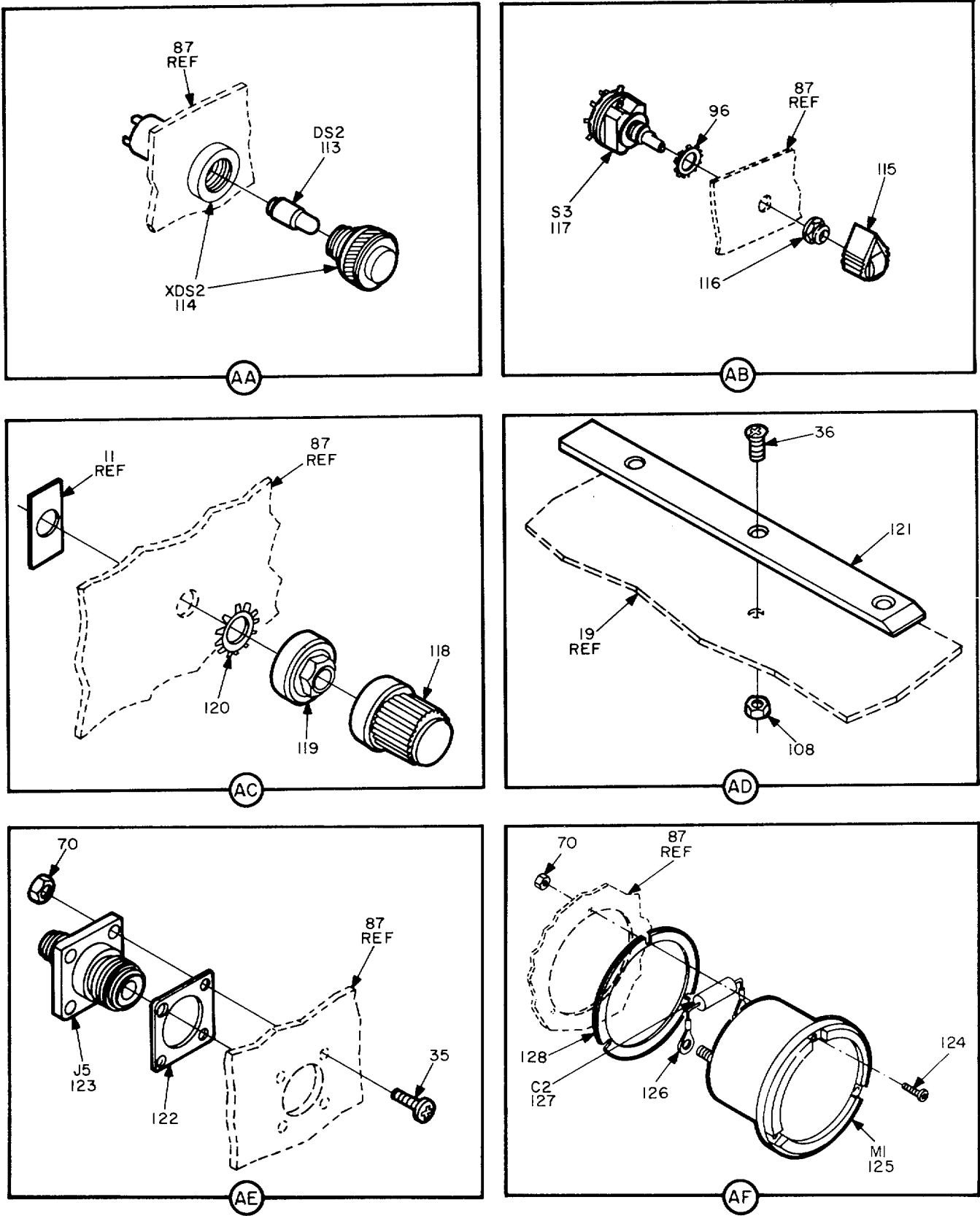

Figure 1. Amplifier-Mixer 6704/TSC (Sheet 8 of 9).

EL60W008

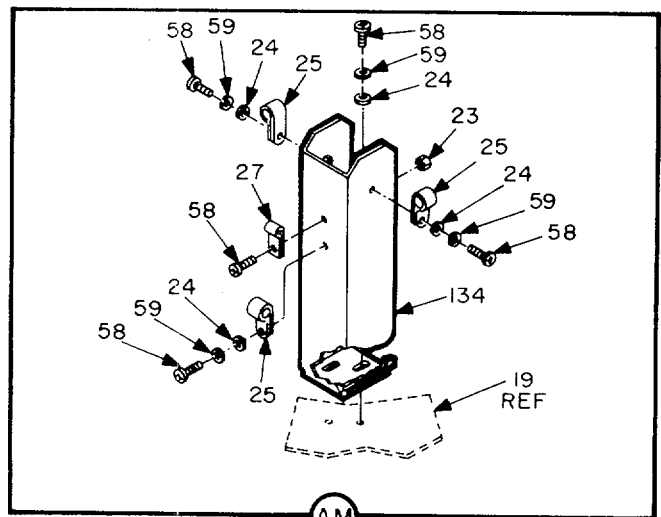
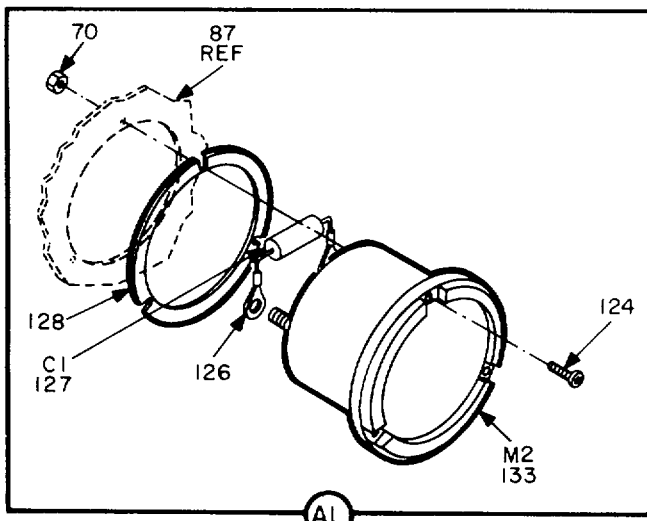
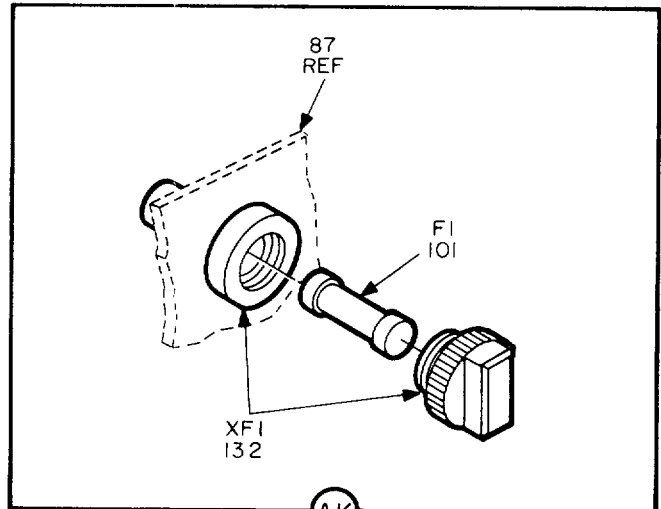
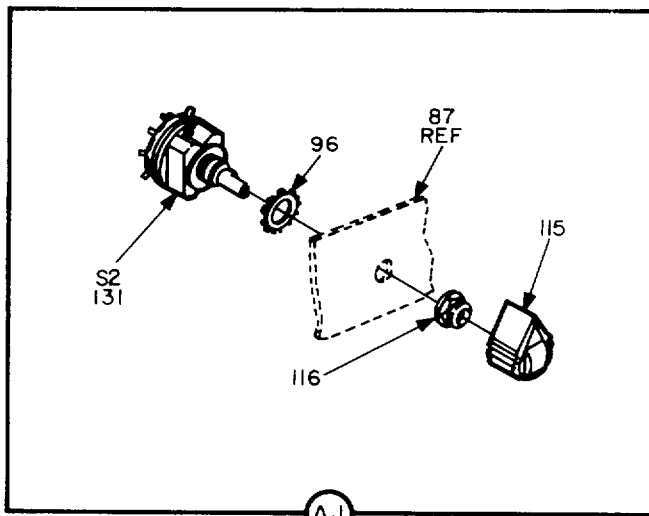
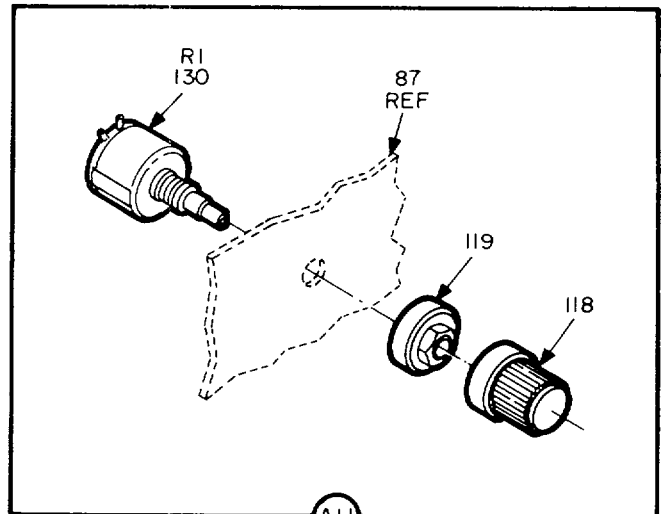
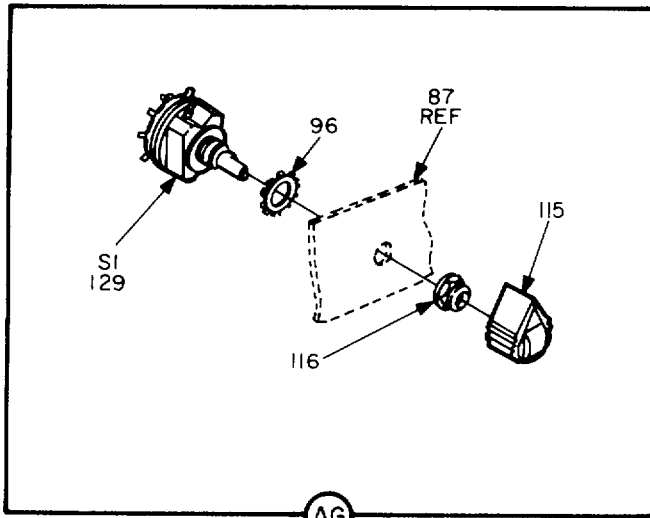

Figure 1. Amplifier-Mixer 6704/TSC (Sheet 9 of 9).

EL6CW009

SECTION II

TM 11-5895-1090-24P

(1) ILLUSTRATION		(2)	(3)	(4)	(5)	(6) DESCRIPTION	(7)	(8)
(a) FIG NO.	(b) ITEM NO.	SMR CODE	NATIONAL STOCK NUMBER	PART NUMBER	FSCM	USABLE ON CODE	U/M	QTY INC IN UNIT
						GROUP 09 AMPLIFIER MIXER AM-6704/TSC		
1	1	PAODL	5895-01-081-0058	SH-D-935082	80063	CHASSIS, ELECTRICAL..... EA	1	
1	2	PAOZZ	5995-01-080-3624	SM-C-936473	80063	CABLE ASSEMBLY, RADI..... EA	1	
1	3	PAOZZ	5995-01-080-3625	SM-C-936472	80063	CABLE ASSEMBLY, RADI..... EA	1	
1	4	XBOZZ		SM-C-936725-2	49671	CABLE ASSY RF..... EA	1	
1	5	PAFZZ	5935-01-014-1444	M39012/55-4026	81349	CONNECTOR PLUG, ELEC..... EA	2	
1	6	PAFZZ	5935-00-762-1495	MS3116F12-10S	96906	CONNECTOR, PLUG, ELEC..... EA	1	
1	7	XBOFF		SM-C-936725-1	49671	CABLE ASSY RF..... EA	1	
1	8	PAODL	5960-01-076-7037	SM-A-775715	49671	ELECTRON TUBE..... EA	1	
1	9	PAOZZ	5995-01-081-0027	SM-C-936714	80063	CABLE ASSEMBLY, RADI..... EA	1	
1	10	PAODL	5895-01-031-0057	SM-D-935081	80063	CHASSIS, ELECTRICAL..... EA	1	
1	11	XBFZZ		SM-B-935334	49671	GASKET SHF DR..... EA	1	
1	12	PAODD	5895-01-081-0056	SM-F-935052	80063	CHASSIS, ELECTRICAL..... EA	1	
1	13	PAOZZ	5995-01-080-3623	SM-C-936471	80063	CABLE ASSEMBLY, RADI..... EA	1	
1	14	MDDZZ		SM-C-936468	49671	BAR, EA	1	
1	15	PADZZ	5305-00-054-5644	MS51957-11	96906	SCREW, MACHINE, EA	4	
1	16	XBFZZ		SM-A-776188-24	49671	PLATE IDENT..... EA	1	
1	17	PADZZ		MS24693-72	96906	SCREW, MACHINE..... EA	4	
1	18	XBFZZ		SM-A-776168-7	49671	HANDLE OVAL..... EA	2	
1	19	XBOZZ		SM-F-935723	49671	CHAS ELEC EQPT..... EA	1	
1	20	XAOZZ		SH-A-916419	49671	CONN PLUG ELECT..... EA	2	
1	21	PAFZZ		UG-5368/U	81349	CONN PLUG ELEC..... EA	1	
1	22	PAFZZ	5935-01-014-1445	M39012/56-3028	81349	CONNECTOR, PLUG, ELEC..... EA	1	
1	23	PADZZ	5310-00-957-1872	MS21045-C08	96906	NUT, S ELF-LOCKING, HE..... EA	17	
1	24	PADZZ	5310-00-880-5978	MS15795-807	96906	WASHER, FLAT..... EA	42	
1	25	PADZZ	5340-00-753-3456	MS25281R2	96906	CLAMP, LOOP..... EA	to	
1	26	PADZZ	5305-00-088-9666	MS24693C51	96906	SCREW, MACHINE..... EA	10	
1	27	PADZZ	5340-00-543-3931	MS25281R3	96906	CLAMP, LOOP..... EA	6	
1	28	PADZZ	5340-00-988-3210	MS25281R4	96906	CLAMP, LOOP..... EA	5	
1	29	PADZZ	5305-00-458-2832	NAS1635-06-6	80205	SCREW, MACHINE..... EA	5	
1	30	PADZZ	5310-00-929-6395	MS35338-136	96906	WASHER, LOCK..... EA	9	
1	31	XBDZZ		SM-C-936420	49671	COVER..... EA	1	
1	32	PADZZ	5310-00-208-3786	NAS671C4	80205	NUT, PLAIN, HEXAGON..... EA	6	
1	33	PADZZ	5310-30-933-8118	MS35336-135	96906	WASHER, LOCK..... EA	13	
1	34	XBFZZ	6645-00-413-0461	MS17325-5	96906	METER, TIME TOTALIZI..... EA	1	
1	35	PADZZ	5305-00-054-5650	MS51957-16	96906	SCREW, MACHINE..... EA	17	
1	36	PADZZ	5305-00-066-7328	MS24693C27	96906	SCR, MACHINE..... EA	7	
1	37	PADZZ	5305-00-054-6654	MS51957-30	96906	SCREW, MACHINE..... EA	2	
1	38	XBDZZ		SM-D-936315	49671	BRKT ELEC PWR, EA	1	
1	39	XBDZZ	5895-01-076-7058	SM-A-935200	49671	POWER SUPPLY..... EA	2	
					5			

SECTION II

TM 11-5895-1090-24P

(1) ILLUSTRATION		(2)	(3)	(4)	(5)	(6) DESCRIPTION	(7)	(8)
(a) FIG NO.	(b) ITEM NO.	SMR CODE	NATIONAL STOCK NUMBER	PART NUMBER	FSCM	USABLE ON CODE	U/M	QTY INC IN UNIT
1	40	PADZZ	5305-00-054-5648	MS51957-14	96906	SCREW, MACHINE.....	EA	7
1	41	PAFZZ	5940-01-021-1844	SM-A-935236-2	80063	TERMINAL, QUICK DISC.....	EA	2
1	42	PADZZ	5340-00-721-5315	MS25281R5	96906	CLAMP, LOOP	EA	2
1	43	XBDZZ		SM-C-890816-3	49671	JUMPER TERM BD.....	EA	5
1	44	PADZZ	5940-00-813-0698	MS25036-101	96906	TERMINAL, LUG	EA	26
1	45	XBDZZ	5310-00-845-5030	NAS1291C08M	80205	NUT, SELF-LOCKING, EX	EA	8
1	46	PADZZ	5940-00-984-4538	38TB9	81349	TERMINAL BOARD.....	EA	2
1	47	XBDZZ		SM-C-890627-19	49671	STRIP TB MARKER	EA	2
1	48	PADZZ	5305-00-088-9670	MS24693C53	96906	SCREW, MACHINE.....	EA	6
1	49	PADZZ	5305-01-029-8874	NAS1635-08-14	80205	SCREW, MACHINE.....	EA	2
1	50	XBFZZ	5935-01-069-6794	M24308/25-1	81349	JACKSCREW, ELEC RICA	EA	2
1	51	PAFZZ	5935-00-465-4378	M24308/1-1	81349	CONNECTOR, RECEPTACL	EA	1
1	52	PAFZZ	5935-01-051-8341	M24308/20-6	81349	SHIELD, ELECTRICAL C	EA	1
1	53	XBDZZ		SM-A-934965	49671	ADAPTER CNN.....	EA	1
1	54	PAFZZ	5935-00-904-4896	MS3116F14-15S	96906	CONNECTOR, PLUG, ELEC	EA	1
1	55	XBDZZ	5305-00-054-5647	MS51957-13	96906	SCREW, MACHINE.....	EA	3
1	56	XBDZZ		SM-C-936121	49671	BRACKET PR MON	EA	1
1	57	PAODL	5895-01-076-7063	SM-A-916470	49671	MONITOR, RADIO FREQU.....	EA	1
1	58	PADZZ	5305-00-054-6670	MS51957-45	96906	SCREW, MACHINE.....	EA	19
1	59	PADZZ	5310-00-933-8119	MS35338-137	96906	WASHER, LOCK	EA	18
1	60	XBDZZ		SM-C-935930	49671	BRACKET ANGLE.....	EA	1
1	61	PAOHH	5895-01-081-0087	SM-D-935507	80063	CIRCUIT CAR ASSEMB.....	EA	1
1	62	XRFZZ	5305-01-071-6364	SM-B-775562-5	49671	SCREW, EXTERNALLY RE	EA	4
1	63	XBDZZ		SM-C-936460	49671	BRACKET ANGLE.....	EA	1
1	64	PAHHA	5895-01-051-3044	SM-D-775384	49671	CIRCUIT CARD ASSEM	EA	1
1	65	PADZZ	5305-00-889-2991	MS24693C48	96906	SCREW, MACHINE.....	EA	5
1	66	XBDZZ		SM-C-935932	49671	BRACKET ANGLE.....	EA	1
1	67	PAFZZ	5935-00-849-7189	MS3110E14-19S	96906	CONNECTOR, RECEPTACL	EA	1
1	68	PADZZ	5305-01-020-0176	NAS1635-04-10	80205	SCREW, MACHINE.....	EA	2
1	69	XBFZZ	5935-00-089-4440	M21097/4-01	81349	CONNECTOR RECEPTACL.....	EA	1
1	70	PADZZ	5310-00-982-5000	MS21045-C04	96906	NUT, SELF-LOCKING, H	EA	16
1	71	XBDZZ		SM-C-935931	49671	BRKT DBL ANGLE	EA	1
1	72	PADZZ	5305-01-030-2255	NAS1635-3-10	80205	SCREW, MACHINE.....	EA	2
1	73	PADZZ	5310-00-619-1148	MS15795-808	96906	WASHER, FLAT	EA	3
1	74	XBDZZ		SM-B-889952	49671	BUMPER	EA	2
1	75	PADZZ	5310-01-065-7120	SM-B-777831	49671	NUT, SPECIAL, HEXAGON	EA	2
1	76	PADZZ	5310-00-184-9161	MS35333-80	96906	WASHER, LOCK	EA	2
1	77	XBDZZ		SM-B-777826	49671	BUSHING	EA	2
1	78	PAFZZ	5935-00-823-0673	MS3110E16-8P	96906	CONNECTOR, RECEPTACL	EA	1
1	79	PADZZ	5305-00-056--9961	MS24693C4	96906	SCREW MACHINE.....	EA	4
					6			

(1) ILLUSTRATION		(2)	(3)	(4)	(5)	(6) DESCRIPTION	(7)	(8)
(a) FIG NO.	(b) ITEM NO.	SMR CODE	NATIONAL STOCK NUMBER	PART NUMBER	FSCM	USABLE ON CODE	U/M	QTY INC IN UNIT
1	80	PADZZ	5305-00-460-0673	NAS1635-3-7	80205	SCREW, MACHINE.....	EA	8
1	81	XBFZZ		SM-D-777131-12	49671	SLIDE QUICK DIS.....	EA	1
1	82	XBDZZ	5305-00-079-5835	MS24693C50	96906	SCREW, MACHINE.....	EA	2
1	83	PADZZ	5305-00-840-5938	MS21318-19	96906	SCREW, DRIVE.....	EA	5
1	84	XBFZZ	5306-01-070-8068	SM-C-775486-6	49671	BOLT, TARGET.....	EA	4
1	85	PADZZ	5330-00-947-4271	NAS1598C3Y	80205	PACKING WITH RETAIN.....	EA	4
1	86	PADZZ	5305-00-054-6669	MS51957-44	96906	SCREW, MACHINE.....	EA	7
1	87	MDDZZ		SM-D-936321	49671	PANEL.....	EA	1
1	88	XBFZZ		SM-D-777132-12	49671	SLIDE QUICK DIS.....	EA	1
1	89	XBDZZ		MS9048-035	96906	PIN.....	EA	1
1	90	PADZZ	5310-00-063-6716	MS35426-14	96906	NUT, PLAIN, WING.....	EA	1
1	91	PADZZ	5310-00-582-5965	MS35338-44	96906	WASHER, LOCK.....	EA	2
1	92	PADZZ	5310-00-809-4058	MS27183-10	96906	WASHER, FLAT.....	EA	1
1	93	PADZZ	5940-00-113-8184	MS25036-150	96906	TERMINAL, LUG.....	EA	5
1	94	XBDZZ		SM-A-777751-1	49671	NUT SHOULDER.....	EA	1
1	95	PADZZ	5305-01-065-7119	SM-B-775557	49671	SCREW, SPECIAL, GROUN.....	EA	1
1	96	PADZZ	5310-00-627-6128	MS35335-35	96906	WASHER, LOCK.....	EA	4
1	97	PADZZ	5310-00-812-4292	NAS671C10	80205	NUT PLAIN HEXAGON.....	EA	1
1	98	PADZZ	5310-00-442-6911	NAS1640-10	80205	WASHER, LOCK.....	EA	1
1	99	PADZZ	5940-00-143-4771	MS25036-103	96906	TERMINAL, LUG.....	EA	3
1	100	PADZZ	5310-00-543-5933	MS35333-73	96906	WASHER, LOCK.....	EA	1
1	101	PAOZZ	5920-00-280-8344	F02A250V1/2A	81349	FUSE, CARTRIDGE.....	EA	2
1	102	PAFZZ	5920-00-556-0144	FHN20G	81349	FUSEHOLDER, EXTRACTO.....	EA	1
1	103	PADZZ	5305-00-082-8440	MS3212-13	96906	SCREW, MACHINE.....	EA	2
1	104	XBDZZ		SM-C-936400	49671	COVER.....	EA	1
1	105	PAOZZ	6240-00-723-3378	M15098/11-002	81349	LAMP, GLOW.....	EA	1
1	106	XBFZZ	6210-00-183-0576	LH88/2	81349	LIGHT, INDICATOR.....	EA	1
1	107	PAFZZ	5925-01-031-4861	M39019/01-218	81349	CIRCUIT BREAKER.....	EA	1
1	108	PADZZ	5310-00-807-1465	MS21042-06	96906	NUT, SELF-LOCKING, EX.....	EA	1
1	109	XBDZZ		SM-B-935322-2	49671	SPACER RUNNER.....	EA	1
1	110	XBDZZ		SM-C-935928	49671	BAR.....	EA	1
1	111	XBOZZ	5930-00-539-7013	M5423/02-01	81349	BOOT, DUST AND MOIST.....	EA	1
1	112	PAFZZ	5930-00-683-1626	MS24523-30	96906	SWITCH, TOGGLE.....	EA	1
1	113	PAOZZ	6240-00-155-7836	MS25237-327	96906	LAMP, INCANDESCENT.....	EA	1
1	114	XBFZZ	6210-01-070-3873	SM-A-916441-2	49671	LIGHT, INDICATOR.....	EA	1
1	115	PAOZZ	5355-00-616-9604	MS91528-1P2B	96906	KNOB.....	EA	3
1	116	XBOZZ	5930-00-182-7474	SM-A-934966-1	49671	BOOT, DUST AND MOIST.....	EA	3
1	117	PAFZZ	5930-01-076-7075	SM-A-916471	49671	SWITCH, ROTARY.....	EA	1
1	118	PAOZZ	5355-00-543-0789	MS91528-1N2B	96906	KNOB.....	EA	2
1	119	PAOZZ	5355-00-055-3497	SM-A-934967	80063	KNOB.....	EA	2

SECTION II

TM 11-5895-1090-24P

(1) ILLUSTRATION		(2)	(3)	(4)	(5)	(6)	(7)	(8)
(a) FIG NO.	(b) ITEM NO.	SMR CODE	NATIONAL STOCK NUMBER	PART NUMBER	FSCM	DESCRIPTION USABLE ON CODE	U/M	QTY INC IN UNIT
1	120	XBDZZ	5310-00-180-0277	MS35333-76	96906	WASHER, LOCK	EA	1
1	121	XBDZZ		SM-B-935322-L	49671	SPACER RUNNER.....	EA	1
1	122	XBFZZ		SM-B-935335	49671	GASKET N/JACK	EA	1
1	123	XBFZZ		SM-A-934976	49671	ADAPTER CON.....	EA	1
1	124	PADZZ	5305-00-054-5653	MS51957-19	96906	SCREW, MACHINE.....	EA	6
1	125	XBFZZ		SM-A-935259-2	49671	METER DC.....	EA	1
1	126	PADZZ	5940-00-254-5216	MS77069-3	96906	TERMINAL, LUG	EA	4
1	127	PAFZZ	5910-01-029-8906	CMR06F102G0DR	81349	CAPACITOR, FIXED MIC.....	EA	2
1	128	XBFZZ	5330-01-070-3986	SM-B-889966	80063	GASKET	EA	2
1	129	PAFZZ	5930-01-076-7076	SM-A-916472	49671	SWITCH, ROTARY	EA	1
1	130	PAFZZ	5905-01-056-1046	SM-A-776959	49671	RESISTOR, VARIABLE.....	EA	1
1	131	PAFZZ	5930-01-076-7077	SM-A-916473	49671	SWITCH, ROTARY	EA	1
1	132	PAFZZ	5920-00-881-6584	FHL17G2	81349	FUSEHOLDER, EXTRACTO.....	EA	1
1	133	PAFZZ	6625-01-076-7116	SM-A-935259-1	49671	METER, ELECTRICAL FR	EA	1
1	134	XBDZZ		SM-C-936769	49671	BRACKET ANGLE.....	EA	1
					8			

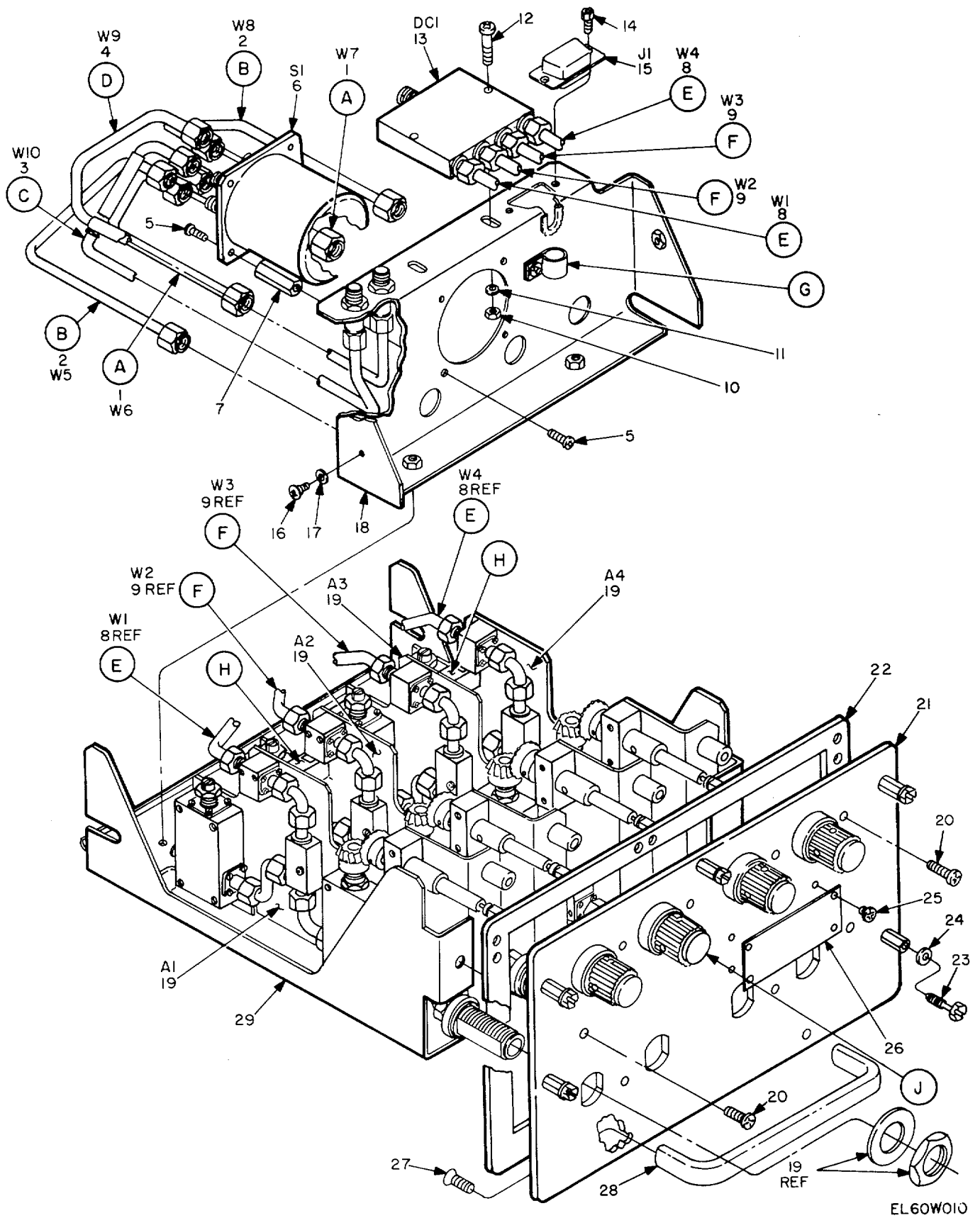

Figure 2. SHF Combiner (Sheet 1 of 2).

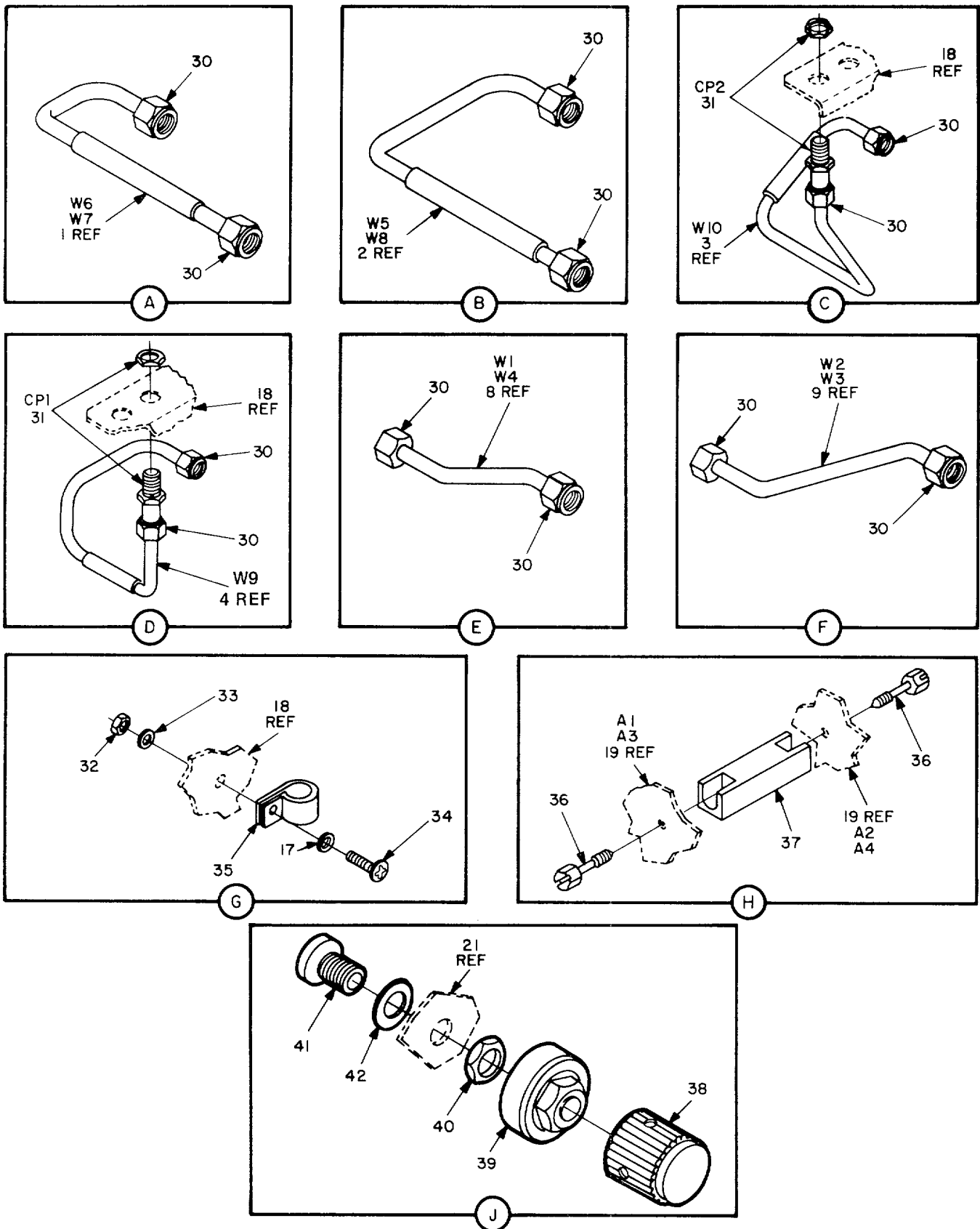

Figure 2. SHF Combiner (Sheet 2 of 2).

EL600W011

SECTION II

TM 11-5895-1090-24P

(1) ILLUSTRATION		(2)	(3)	(4)	(5)	(6)	(7)	(8)
(a) FIG NO.	(b) ITEM NO.	SMR CODE	NATIONAL STOCK NUMBER	PART NUMBER	FSCM	DESCRIPTION USABLE ON CODE	U/M	QTY INC IN UNIT
						GROUP 0901 SHF COMBINER		
2	1	PAHZZ	5995-01-081-0022	SM-C-935973	80063	CABLE ASSEMBLY, RADI.....	EA	2
2	2	PAHZZ	5995-01-081-0021	SM-C-935974	80063	CABLE ASSEMBLY, RADI.....	EA	2
2	3	PAHZZ	5995-01-081-0024	SM-C-935980	80063	CABLE ASSEMBLY, RADI.....	EA	1
7	4	PAHZZ	5995-01-081-0023	SM-C-935979	80063	CABLE ASSEMBLY, RADI.....	EA	1
2	5	PADZZ	5305-00-241-1076	NAS1635-04-5	80205	SCREW, MACHINE.....	EA	8
2	6	XBDZA	5985-00-076-6946	SM-A-935198	49671	SWITCH, RADIO FREQUE.....	EA	1
2	7	XBDZZ		SM-C-936484	49671	POST ELEC MECH.....	EA	4
2	8	PAFZZ	5995-01-081-0025	SM-C-936483	80063	CABLE ASSEMBLY, RADI.....	EA	2
2	9	PAHZZ		SM-C-936482	49671	CABLE ASSY R.....	EA	2
2	10	PADZZ	5310-00-982-5003	MS21045C06	96906	NUT, SELF-LOCKING, HE.....	EA	2
2	11	PADZZ	5310-30-722-5998	MS15795-805	96906	WASHER, FLAT.....	EA	2
2	12	PAOZZ	5305-00-054-6656	MS51957-32	96906	SCREW, MACHINE.....	EA	2
2	13	XBDZA	5895-01-076-6945	SM-A-916478	49671	POWER COMBINER.....	EA	1
2	14	XBFZZ	5905-00-111-4734	RCR20G470JS	81349	RESISTOR, FIXED, COMP.....	EA	1
2	15	PADZZ	5935-00-410-9251	MS24308/3-1	81349	CONNECTOR, RECEPTACL.....	EA	1
2	16	PADZZ	5305-01-020-0178	NAS1635-08-7	80205	SCREW, MACHINE.....	EA	2
2	17	PADZZ	5310-00-880-5978	MS15795-807	96906	WASHER, FLAT.....	EA	2
2	18	MDDZZ		SM-D-935578	49671	BRACKET.....	EA	1
2	19	PAFDL	5895-01-076-6947	SM-D-935053	49671	CHANNEL ASSEMBLY RF.....	EA	4
2	20	PADZZ	5305-00-054-6669	MS51957-44	96906	SCREW, MACHINE.....	EA	9
2	21	MDOZZ		SM-D-936323	49671	PANEL.....	EA	1
2	22	XBDZZ		SM-C-935986	49671	GASKET.....	EA	1
2	23	XBFZZ	5305-01-072-4419	SM-B-775562-3	49671	SCREW, EXTERNALLY RE.....	EA	5
2	24	XBDZZ	5330-00-853-3975	NAS1598C06Y	80205	PACKING WITH RETAIN.....	EA	5
2	25	PADZZ	5305-00-738-0624	MS3212-1	96906	SCREW PAN HEAD.....	EA	4
2	26	XBFZZ		SM-B-935347	49671	PLATE CAUTION.....	EA	1
2	27	PADZZ	5305-00-780-1131	MS24693C72	96906	SCREW, MACHINE.....	EA	2
2	28	XBDZZ		SM-A-776168-1	49671	HANDLE OVAL.....	EA	1
2	29	XBDZZ		SM-D-935577	49671	CHAS ELEC EQPT.....	EA	1
2	30	XAHZZ		SM-A-916419	49671	CONN PLUG ELECI.....	EA	2
2	31	XBDZZ		SM-A-935195-2	49671	JACK BHD FD THR.....	EA	2
2	32	PADZZ	5310-00-837-1381	NAS671C8	80205	NUT, PLAIN, HEXAGON.....	EA	1
2	33	PAOZZ	5310-00-933-8119	MS35338-137	96906	WASHER, LOCK.....	EA	1
2	34	PAOZZ	5305-00-403-3465	NAS1635-08-10	80205	SCREW, MACHINE.....	EA	1
2	35	PADZZ	5340-00-543-3931	MS25281R3	96906	CLAMP, LOOP.....	EA	1
2	36	XBFZZ	5305-01-074-3352	SM-B-775562-1	49671	SCREW, EXTERNALLY RE.....	EA	4
2	37	XBDZZ		SM-C-935985	49671	SPACER.....	EA	2
2	38	PAOZZ	5355-00-543-0789	MS91528-1N2B	96906	KNOB.....	EA	4
2	39	PAOZZ	5355-00-055-3497	SM-A-934967	80063	KNOB.....	EA	4

SECTION II

TM 11-5895-1090-24P

(1) ILLUSTRATION		(2)	(3)	(4)	(5)	(6) DESCRIPTION	(7)	(8)
(a) FIG NO.	(b) ITEM NO.	SMR CODE	NATIONAL STOCK NUMBER	PART NUMBER	FSCM	USABLE ON CODE	U/M	QTY INC IN UNIT
2	40	PADZZ	5310-00-138-9806	MS25082C20	96906	NUT, PLAIN, HEXAGON	EA	4
2	41	XBDZZ		SN-8-935303	49671	BUSH RF CHANNEL	EA	4
2	42	XBDZZ		SN-9-35304	49671	GASKET RF CHAN	EA	4

12/(13 BLANK)

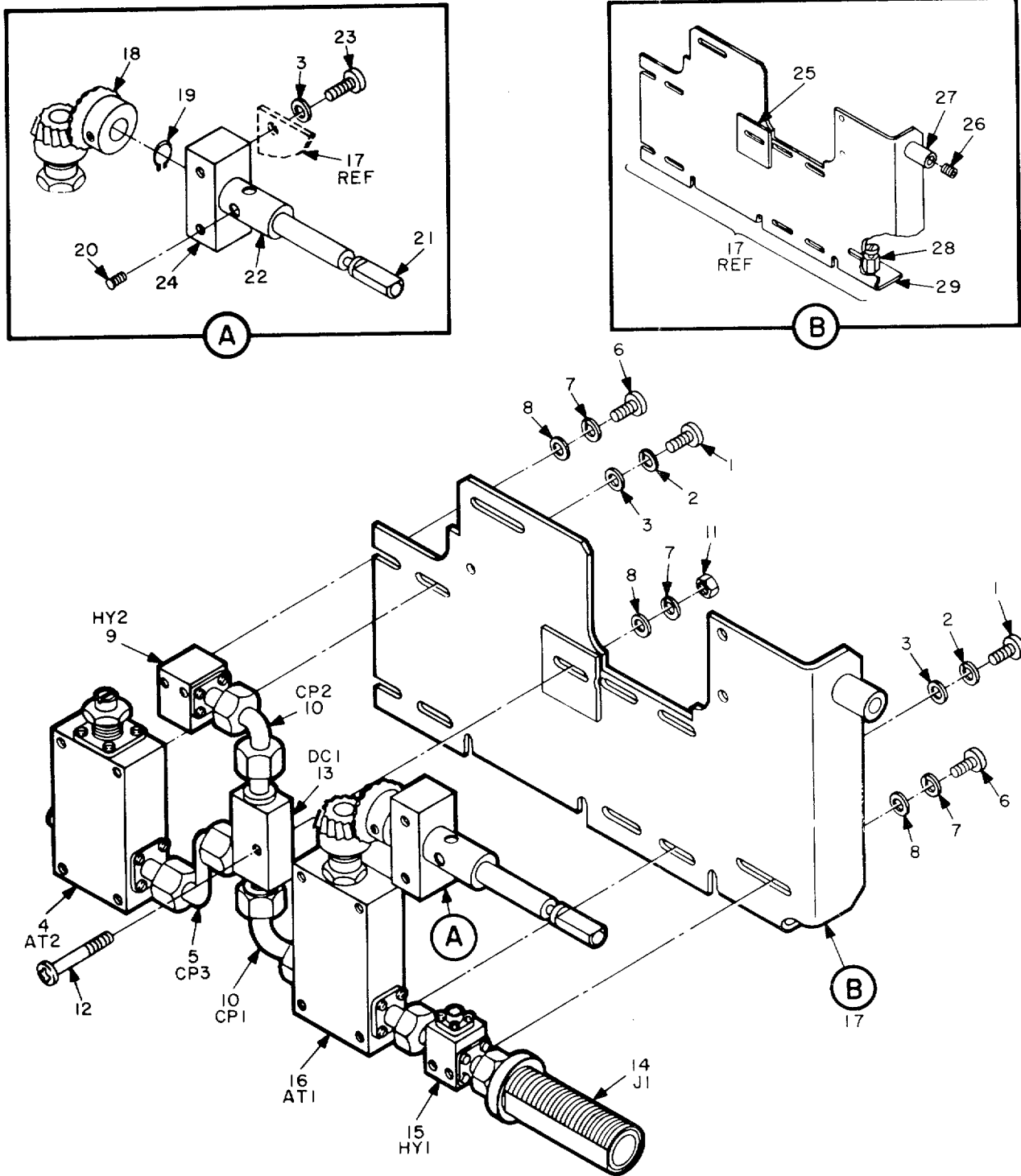

EL60W012

Figure 3. SHF Channel Assembly.

SECTION II

TM 11-5895-1090-24P

(1) ILLUSTRATION		(2)	(3)	(4)	(5)	(6) DESCRIPTION	(7)	(8)
(a) FIG NO.	(b) ITEM NO.	SMR CODE	NATIONAL STOCK NUMBER	PART NUMBER	FSCM	USABLE ON CODE	U/M	QTY INC IN UNIT
						GROUP 090101 SHF CHANNEL ASSEMBLY		
3	1	PADZZ	5305-00-054-5647	MS51957-13	96906	SCREW, MACHINE.....	EA	8
3	2	PADZZ	5310-00-933-8118	MS35338-135	96906	WASHERLOCK.....	EA	8
3	3	PADZZ	5310-00-595-6211	MS15795-803	96906	WASHER, FLAT.....	EA	10
3	4	PADZZ	5985-01-056-1091	SM-A-776957	49671	ATTENUATOR, VARIABLE.....	EA	1
3	5	XBDZZ		SM-A-935843-2	49671	ADAPTER CONN.....	EA	1
3	6	PADZZ	5305-00-054-5638	MS51957-4	96906	SCREW, MACHINE.....	EA	4
3	7	PADZZ	5310-00-928-2690	MS35338-134	96906	WASHER, LOCK.....	EA	5
3	8	PADZZ	5310-00-595-6761	MS15795-802	96906	WASHER, FLAT.....	EA	5
3	9	PBDZZ	5985-01-056-1037	SM-A-775612	80063	ISOLATOR, RADIO FREQ.....	EA	1
3	10	XBDZZ		SM-A-935843-1	49671	ADAPTER CONN.....	EA	2
3	11	PADZZ	5310-00-938-2013	MS35649-224	96906	NUT, PLAIN, HEXAGON.....	EA	1
3	12	PADZZ	5305-00-054-5643	MS51957-9	96906	SCREW, MACHINE.....	EA	1
3	13	XBDZZ		SM-A-935804-1	49671	COUPLER DIRECT.....	EA	1
3	14	XBOZZ		SM-A-936511	49671	ADAPTER CONN.....	EA	1
3	15	XBDZZ	5985-01-076-6948	SM-A-935270	49671	ISOLATOR, RADIO FRE.....	EA	1
3	16	PADZZ	5985-01-081-0020	SM-A-935269	80063	ATTENUATOR, VARIABLE.....	EA	1
3	17	XBODL		SM-D-935579	49671	CHAS ELEC EQPT.....	EA	1
3	18	XBDZZ		P1C #N3-1	00141	GEAR MATCHED PR.....	EA	1
3	19	XBOZZ		MS166244025	96906	RING RETAINING.....	EA	1
3	20	XBDZZ	5305-00-582-8843	AN56504H1	88044	SETSCREW.....	EA	2
3	21	XBDZZ		SM-B-935306	49671	SHAFT ADJ.....	EA	1
3	22	XBDZZ		SM-B-935305	49671	SHAFT GEAR.....	EA	1
3	23	PADZZ	5305-00-068-5276	MS16995-9	96906	SCREW, CAP, SOCKET HE.....	EA	2
3	24	XBDZZ		SM-C-935939	49671	SUPPORT.....	EA	1
3	25	XBDZZ		SM-D-935579-5	49671	SPACER.....	EA	1
3	26	XBDZZ		MS2109C0820L	96906	INSERT.....	EA	1
3	27	XBDZZ		SM-D-935579-2	49671	BUSHING.....	EA	1
3	28	XBDZZ		SM-A-934961-I	49671	RETAINER.....	EA	2
3	29	XBDZZ		SM-D-935579-1	49671	CHASSIS.....	EA	1

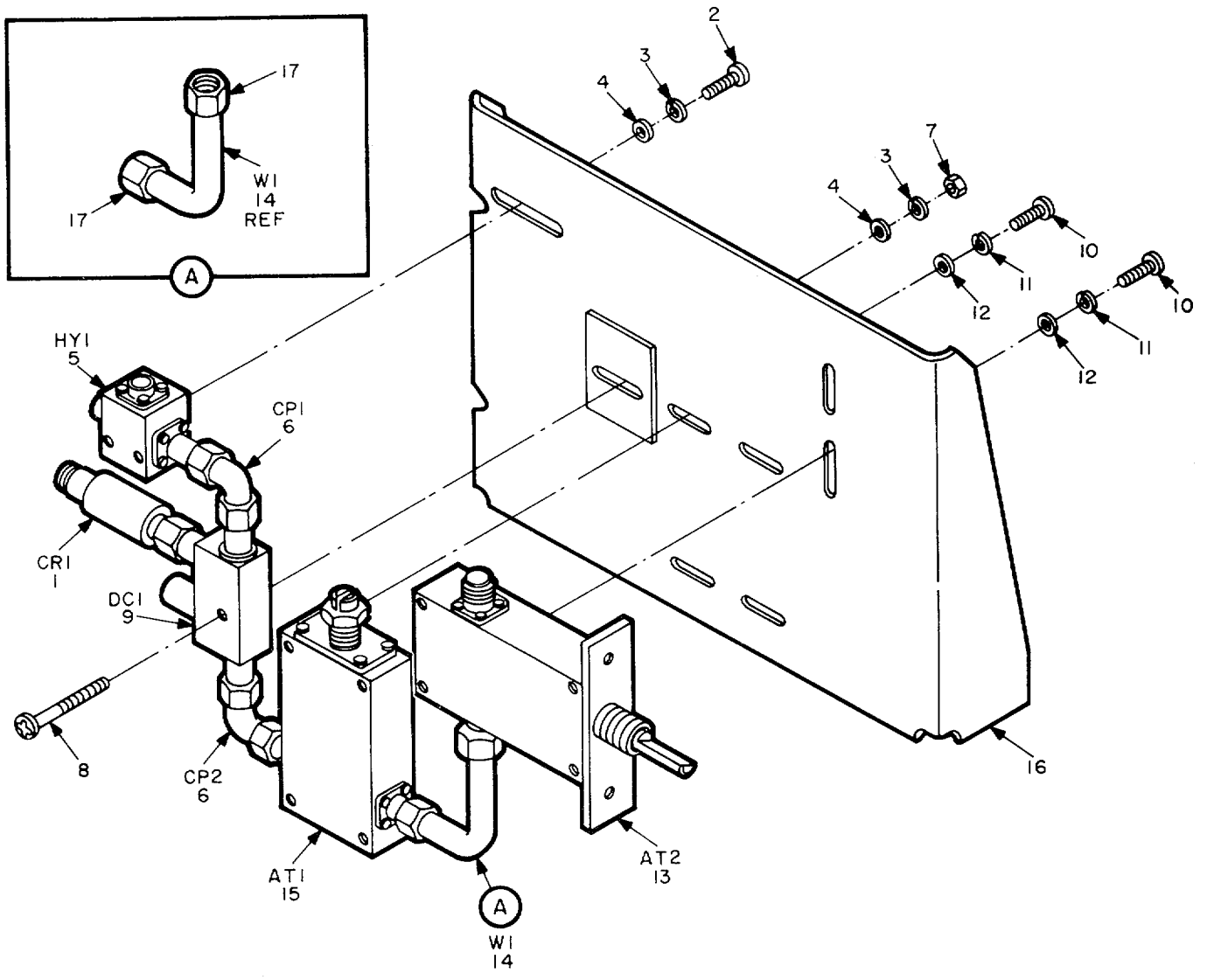

EL60W013

Figure 4. SHF Drive Assembly.

SECTION II

TM 11-5895-1090-24P

(1) ILLUSTRATION		(2)	(3)	(4)	(5)	(6) DESCRIPTION	(7)	(8)
(a) FIG NO.	(b) ITEM NO.	SMR CODE	NATIONAL STOCK NUMBER	PART NUMBER	FSCM	USABLE ON CODE	U/M	QTY INC IN UNIT
						GROUP 0902 SHF DRIVE ASSEMBLY		
4	1	XBDZZ	6625-00-361-8530	SM-A-776170-2	49671	DIODE D ETECTOR.....	EA	1
4	2	PADZZ	5305-00-054-5636	MS51957-2	96906	SCREW, MACHINE.....	EA	2
4	3	PADZZ	5310-00-928-2690	MS35338-134	96906	WASHER, LOCK.....	EA	3
4	4	PADZZ	5310-00-595-6761	MS15795-802	96906	WASHER, FLAT.....	EA	3
4	5	PBDZZ	5985-01-056-1037	SM-A-775612	80063	ISOLATOR, RADIO FREQ.....	EA	1
4	6	XBDZZ		SM-A-935843-1	49671	ADAPT RF CABLE.....	EA	2
4	7	PADZZ	5310-00-938-2013	MS35649-224	96906	NUT, PLAIN, HEXAGON.....	EA	1
4	8	PADZZ	5305-00-054-5643	MS51957-9	96906	SCREW, MACHINE.....	EA	1
4	9	XBDZZ		SM-A-935804-1	49671	COUPLER DIRECT.....	EA	1
4	10	PADZZ	5305-00-054-5647	MS51957-13	96906	SCREW, MACHINE.....	EA	6
4	11	XBDZZ	5310-00-442-6913	NAS1640-4	80205	WASHER, LOCK.....	EA	6
4	12	PADZZ	5310-00-595-6211	MS15795-803	96906	WASHER, FLAT.....	EA	6
4	13	PADZZ	5985-01-056-1090	SM-A-775613	49671	ATTENUATOR VARIABLE.....	EA	1
4	14	XBDZZ		SM-C-935963	49671	CABLE ASSY RF.....	EA	1
4	15	PADZZ	5985-01-056-1091	SM-A-776957	49671	ATTENUATOR, VARIABLE.....	EA	1
4	16	XBDZZ		SM-D-935582	49671	CHAS ELEC EQPT.....	EA	1
4	17	XADZZ		RCR20G822JS	81349	RESISTOR, FIXED, COMP.....	EA	2

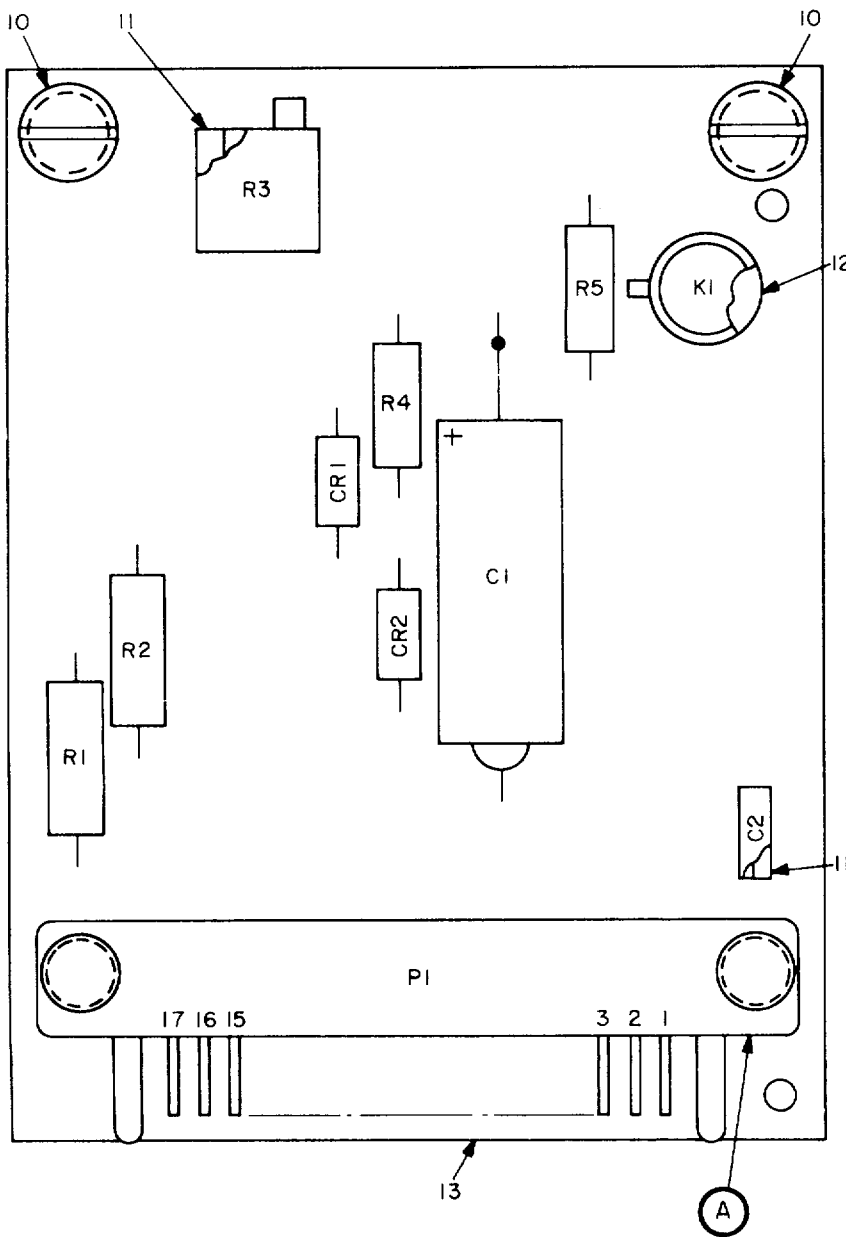

LEGEND

REF NO	ITEM NO
C1	1
C2	2
CR1	3
CR2	4
K1	4
PI	5
R1	6
R2	7
R3	8
R4	9
R5	9

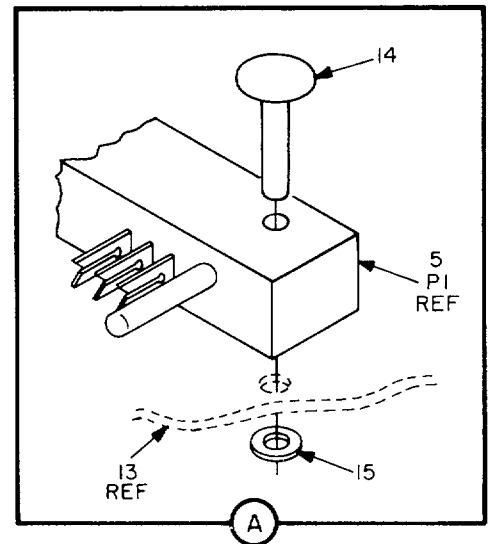

EL60W014

Figure 5. Transient Suppressor.

SECTION II

TM 11-5895-1090-24P

(1) ILLUSTRATION		(2)	(3)	(4)	(5)	(6) DESCRIPTION	(7)	(8)
(a) FIG NO.	(b) ITEM NO.	SMR CODE	NATIONAL STOCK NUMBER	PART NUMBER	FSCM	USABLE ON CODE	U/M	QTY INC IN UNIT
						GROUP 0904 TRANSIENT SUPPRESSOR		
5	1	PAHZZ	5910-01-084-3516	M39006/09-8279	81349	CAPACITOR, FIXED, ELE	EA	1
5	2	PAHZZ	5910-01-041-9159	M39014/02-1240	81349	CAPACITOR, FIXED, CER.....	EA	1
5	3	PAHZZ	5961-00-087-6047	JAN1N645	81349	SEMICONDUCTOR DEVIC.....	EA	2
5	4	PAHZZ	5945-00-256-0669	MS757/70-002	81349	RELAY, ELECTROMAGNET	EA	1
5	5	XBHZZ	5935-00-089-4858	M21097/5-01	81349	CONNECTOR, RECEPTACL.....	EA	1
5	6	PAHZZ	5905-00-189-2468	RNC60K3482FS	81349	RESISTOR, FIXED, FILM.....	EA	1
5	7	PAHZZ	5905-00-192-3479	RNC60K9091FS	81349	RESISTOR, FIXED, FILM.....	EA	1
5	8	XBHZZ		RJR24CP503M	81349	RES VAR NON WW	EA	1
5	9	PAHZZ	5905-00-116-8569	RCR20G821JS	81349	RESISTOR, FIXED, COMP.....	EA	2
5	10	XBHZZ		SM-A-935828-1	49671	SCREW PANEL	EA	2
5	11	XBHZZ		SM-A-775541	49671	SPACER.....	EA	5
5	12	XBHZZ		SM-B-775546	49671	SPACER.	EA	1
5	13	PAHZZ	5999-01-081-0100	SM-D-935590	80063	PRINTED WIRING BOAR	EA	1
5	14	XBHZZ	5320-00-993-0679	MS16535-163	96906	RIVET, TUBULAR	EA	2
5	15	PAHZZ	5310-00-595-6211	MS15795-803	96906	WASHER, FLAT	EA	2

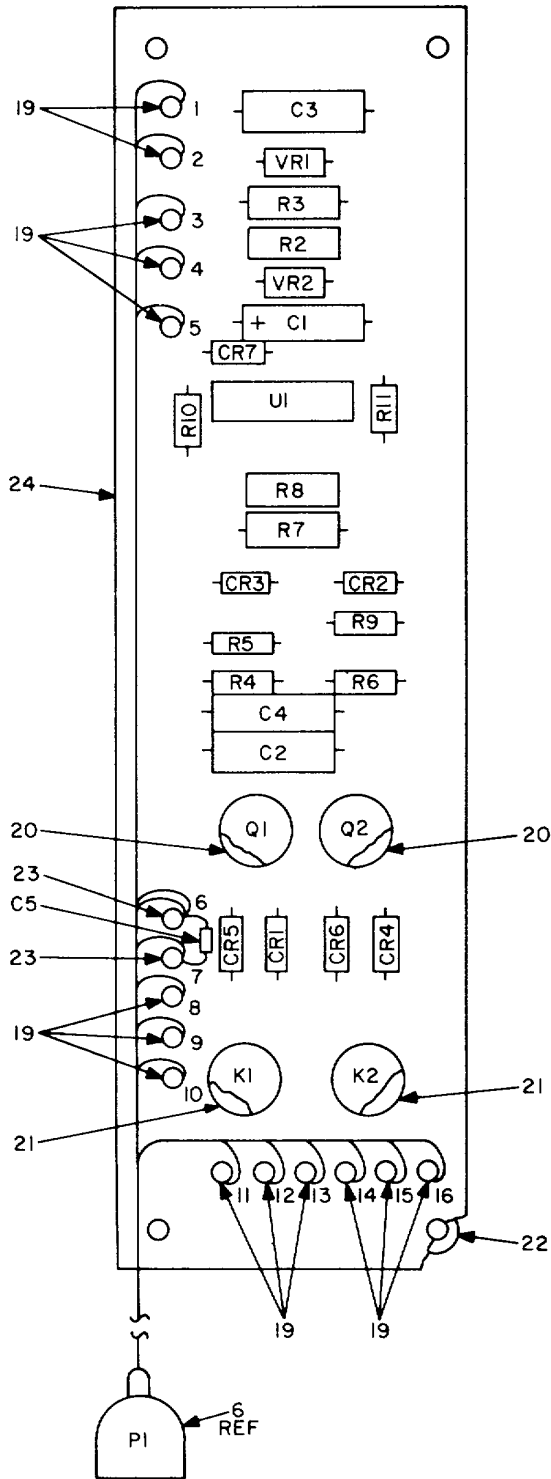

LEGEND

REF NO	ITEM NO	REF NO	ITEM NO
C1	1	Q1	7
C2	2	Q2	7
C3	1	R2	8
C4	2	R3	9
C5	3	R4	10
CR1	4	R5	11
CR2	4	R6	10
CR3	4	R7	12
CR4	4	R8	13
CR5	4	R9	14
CR6	4	R10	15
CR7	4	R11	15
K1	5	UI	16
K2	5	VR1	17
PI	6	VR2	18

Figure 6. RF Low Power Alarm.

EL60W015

SECTION II

TM 11-5895-1090-24P

(1) ILLUSTRATION		(2)	(3)	(4)	(5)	(6) DESCRIPTION	(7)	(8)
(a) FIG NO.	(b) ITEM NO.	SMR CODE	NATIONAL STOCK NUMBER	PART NUMBER	FSCM	USABLE ON CODE	U/M	QTY INC IN UNIT
						GROUP 0905 RF LOW POWER ALARM		
6	1	PAHZZ	5910-00-219-1864	M39003/01-2245	81349	CAPACITOR, FIXED, ELE	EA	2
6	2	PAHZZ	5910-00-409-9879	M39003/01-5031	81349	CAPACITOR, FIXED, ELE	EA	2
6	3	PAHZZ	5910-00-600-6889	M39014102-1230	81349	CAPACITOR, FIXED, CER.....	EA	1
6	4	PAHZZ	5961-00-938-1135	JAN1N4148	81349	SEMICONDUCTOR DEVIC.....	EA	7
6	5	PAHZZ	5945-00-256-0669	M5757/70-002	81349	RELAY, ELECTROMAGNET.....	EA	2
6	6	PAHZZ	5935-00-779-8294	MS3116F1-19P	96906	CONNECTOR, PLUG, ELE	EA	1
6	7	PAHZZ	5961-00-949-1432	JAN2N2219A	81349	TRANSISTOR	EA	2
6	8	PAHZZ	5905-01-016-1038	RNR60C5111FM	81349	RESISTOR, FIXED, FILM	EA	1
6	9	PAHZZ	5905-00-760-0327	RNR60C7SR0FS	81349	RESISTOR, FIXED, FILM.....	EA	1
6	10	PAHZZ	5905-00-141-1183	RCR07G101JS	81349	RESISTOR, FIXED, COMP	EA	2
6	11	PAHZZ	5905-00-463-9990	RCR07G332KM	81349	RESISTOR, FIXED, COMP	EA	1
6	12	PAHZZ	5905-01-061-3871	RNR60C3012FM	81349	RESISTOR, FIXED, FILM.....	EA	1
6	13	PAHZZ	5905-00-232-2946	RNR60C1000FS	81349	RESISTOR, FIXED, FILM.....	EA	1
6	14	PAHZZ	5905-00-114-5343	RCR07G182JS	81349	RESISTOR, FIXED, COMP	EA	1
6	15	PAHZZ	5905-00-110-0388	RCR07G104JM	81349	RESISTOR, FIXED, COMP	EA	2
6	16	PAHZZ		SM-A-937086	49671	MICROCIRCUIT, LINEAR	EA	1
6	17	PAHZZ	5961-00-833-3043	JAN1N757A	81349	SEMICONDUCTOR DEVIC.....	EA	1
6	18	PAHZZ	5961-00-847-5246	JAN1N746A	81349	SEMICONDUCTOR DEVIC	EA	1
6	19	XBHZZ		SM-B-447366-2	49671	TERMINAL STUD	EA	14
6	20	PAHZZ	5999-01-054-6449	M38527/3-010	81349	MOUNTING PAD, ELECTR.....	EA	2
6	21	PAHZZ		M38527/11-2181	81349	MOUNTING PAD, ELECTR.....	EA	2
6	22	XBHZZ		SM-A-916427	49671	FASTENER	EA	4
6	23	XBHZZ		SM-B-447176-4	49671	TERMINAL STUD.....	EA	2
6	24	XBHZZ		SM-D-77T166	49671	BOARD PW	EA	1

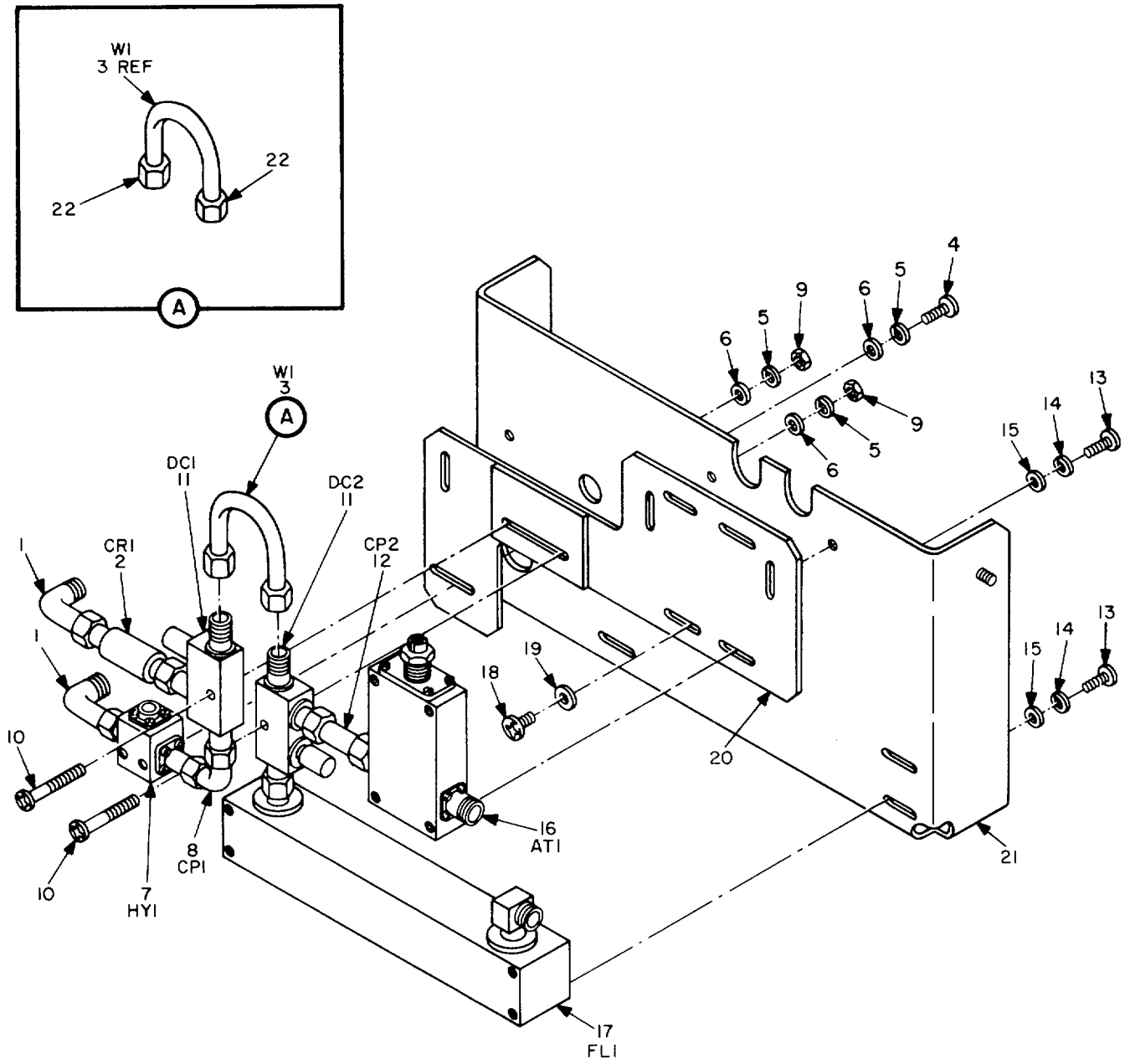

EL60W016

Figure 7. SHF Output.

SECTION II

TM 11-5895-1090-24P

(1) ILLUSTRATION		(2)	(3)	(4)	(5)	(6) DESCRIPTION	(7)	(8)
(a) FIG NO.	(b) ITEM NO.	SMR CODE	NATIONAL STOCK NUMBER	PART NUMBER	FSCM	USABLE ON CODE	U/M	QTY INC IN UNIT
						GROUP 0906 SHF OUTPUT		
7	1	XBDZZ		SM-A-937257	49671	ADAPTER CONN	EA	2
7	2	XBDZZ	6625-00-361-8530	SM-A-176170-2	49671	DIODE DETECTOR.....	EA	1
7	3	PADZZ	5995-01-081-0026	SM-C-935962	80063	CABLE ASSEMBLY, RADI	EA	1
7	4	PADZZ	5305-00-054-5638	MS51957-4	96906	SCREW, MACHINE.....	EA	2
1	5	PADZZ	5310-00-928-2690	MS35338-134	96906	WASHER, LOCK	EA	4
7	6	PADZZ	5310-00-595-6761	MS15795-802	96906	WASHER, FLAT	EA	4
7	7	PBDZZ	5985-01-056-1037	SM-A-775612	80063	ISOLATOR, RADIO FREQ	EA	1
7	7	XBDZZ		SM-A-935843-1	49671	ADAPT RF CABLE	EA	1
7	9	PADZZ	5310-00-938-2013	MS35649-224	96906	NUT, PLAIN, HEXAGON.....	EA	2
7	10	PADZZ	5305-00-054-5643	MS51957-9	96906	SCREW, MACHINE.....	EA	2
7	11	X8DZZ		SM-A-935804-2	49671	COUPLER DIRECT.....	EA	2
7	12	XBDZZ	5985-01-076-7043	SM-A-934947-1	49671	COUPLER, TRANSMISSIO.....	EA	1
7	13	PADZZ	5305-00-054-5649	MS51957-15	96906	SCREW, MACHINE.....	EA	8
7	14	PADZZ	5310-00-933-8118	MS35338-135	96906	WASHER, LOCK	EA	8
7	15	PADZZ	5310-00-595-6211	MS15795-803	96906	WASHER, FLAT	EA	8
7	16	PADZZ	5985-01-056-1091	SM-A-776957	49671	ATTENUATOR, VARIABLE	EA	1
7	17	PADZZ	5915-01-080-9999	SM-A-935256	80063	FILTER, BAND PASS.....	EA	1
7	18	PADZZ	5305-00-054-6654	MS51957-30	96906	SCREW, MACHINE.....	EA	3
7	19	PADZZ	5310-00-722-5998	MS15795-805	96906	WASHER, FLAT	EA	3
7	20	MDDZZ		SM-C-935485	49671	PLATE MOUNTING.....	EA	1
7	21	XBDZZ		SM-D-935586	49671	CHASS ELEC EQPT	EA	1
7	22	XADZZ		SM-A-916419	49671	CONN PLUG ELECT	EA	2

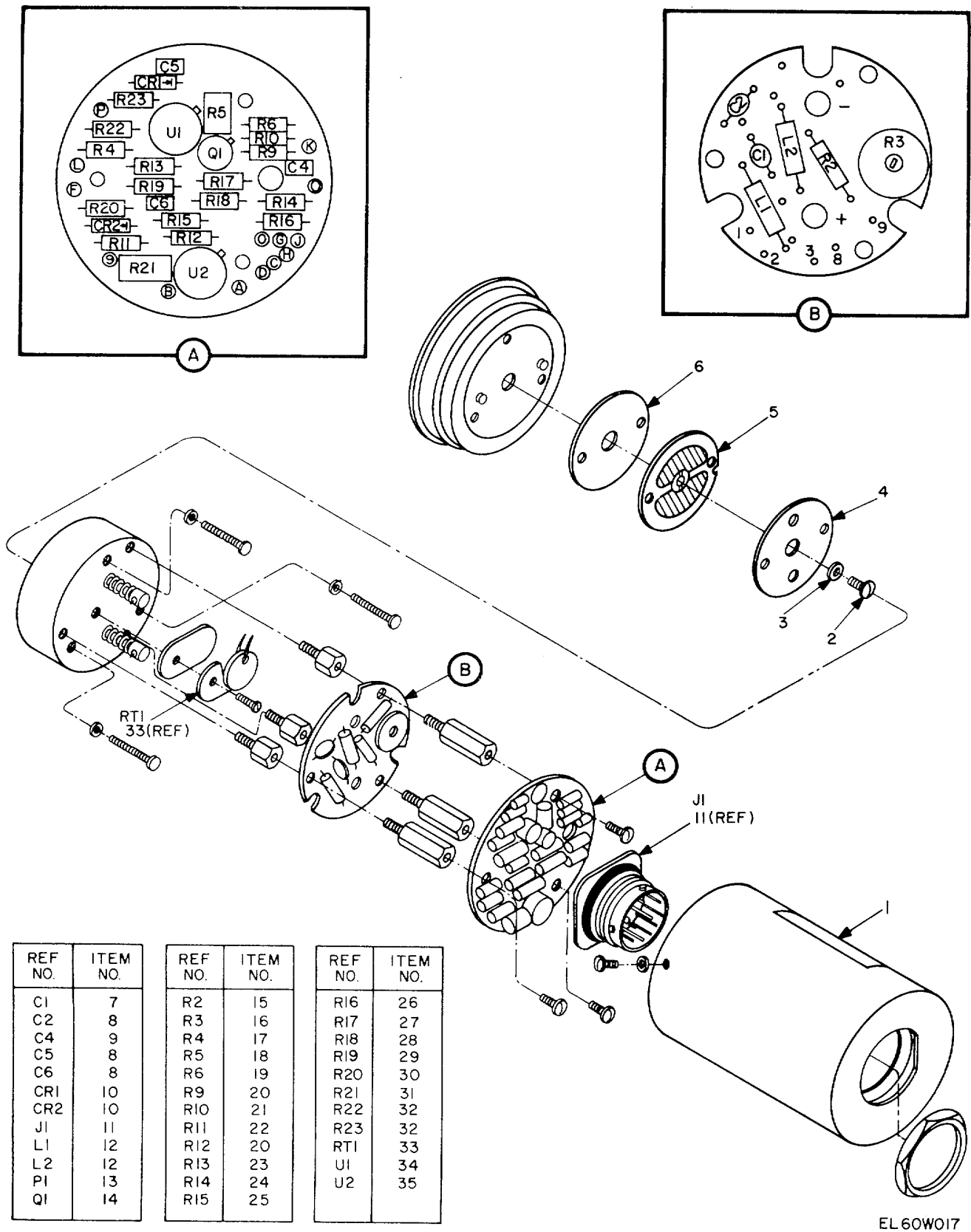

EL60W017

Figure 8. Thermolectric Power Monitor.

SECTION II

TM 11-5895-1090-24P

(1) ILLUSTRATION		(2)	(3)	(4)	(5)	(6)	(7)	(8)
(a) FIG NO.	(b) ITEM NO.	SMR CODE	NATIONAL STOCK NUMBER	PART NUMBER	FSCM	DESCRIPTION USABLE ON CODE	U/M	QTY INC IN UNIT
						GROUP 0908 THERMOELECTRIC POWER MONITOR		
8	1	XBDZZ		3928G	11332	PLATE CALIBRATION	EA	1
8	2	XBDZZ	5305-01-058-1232	7936A-8	11332	SCREW, INSTRUMENT	EA	1
8	3	XBDZZ		3017F	11332	WASHER	EA	1
8	4	XBDZZ		3155F-1	11332	REAR COVER SHEET	EA	1
8	5	PADZZ	6625-00-431-8999	TL-2A	11332	FILM ELEMENT.....	EA	1
8	6	XBDZZ		3155F-3	11332	FRONT COVER SHEET.....	EA	1
8	7	PADZZ		812150-651-104M	72982	CAPACITOR, FIXED, CER.....	EA	1
8	8	PADZZ	5910-00-810-4849	TG-S10	56289	CAPACITOR, FIXED, CER.....	EA	3
8	9	PADZZ	5910-01-015-9236	CK058X472M	81349	CAPACITOR FIXED PAP	EA	1
a	10	PADZZ	5961-00-938-1135	JAN1N4148	81349	SEMICONDUCTOR DEVIC.....	EA	2
8	11	PADZZ	5935-01-088-2849	BT07A14-15P	09922	CONNECTOR, RECEPTACL.....	EA	1
8	12	PADZZ	5950-01-007-5762	3362D	11332	COIL, RADIO FREQUENC.....	EA	2
B	13	PADZZ	5935-00-783-2071	MS3116E14-15S	96906	CONNECTOR, PLUG, ELEC	EA	1
8	14	PADZZ	5920-00-142-7439	2N2222A	81349	FUSEHOLDER, BLOCK	EA	1
8	15	PADZZ	5905-00-810-1055	RN60C1000F	81349	RESISTOR, FIXED, FILM.....	EA	1
8	16	PADZZ	5905-00-739-6693	84-3-8-101	02111	RESISTOR, VARIABLE, W	EA	1
8	17	PADZZ		CMF55T22000HMS	91637	RESISTOR, FIXED FILM	EA	1
8	18	PADZZ	5905-01-008-2882	850-208-10K	77630	RESISTOR, VARIABLE, N	EA	1
8	19	PADZZ	5905-00-681-6462	RC07GF102J	81349	RESISTOR, FIXED, COMP	EA	1
8	20	PADZZ	5905-00-683-7720	RC07GF510J	81349	RESISTOR, FIXED, COMP	EA	2
8	21	PADZZ	5905-00-682-4101	RC07GF752J	81349	RESISTOR, FIXED, COMP	EA	1
8	22	PADZZ		CMF55T21000HMS	91637	RESISTOR, FIXED FILM.....	EA	1
8	23	PADZZ		CMF55T 294K0HMS	91637	RESISTOR, FIXED, FILM.....	EA	1
8	24	PADZZ		CMF55T2665.3 0HMS	91637	RESISTOR, FIXED FILM.....	EA	1
8	25	PADZZ		CMF55T214.2 K0HMS	91637	RESISTOR, FIXED FILM.....	EA	1
8	26	PADZZ		CMF55T1149.5K 0HM	91637	RESISTOR, FIXED FILM.....	EA	1
8	27	PADZZ		CMF55T249900 HMS	91637	RESISTOR, FIXED FILM.....	EA	1
8	28	PADZZ		CMF55T210000MS	91637	RESISTOR, FIXED FILM	EA	1
8	29	PADZZ		CMF55T2100K 0HMS	91637	RESISTOR, FIXED FILM.....	EA	1
8	30	PADZZ	5905-00-922-9755	RN55C1020F	81349	RESISTOR, FIXED, FILM.....	EA	1
8	31	PADZZ	5905-01-089-0613	76-70-10K	58022	RESISTOR, VARIABLE, N	EA	1
8	32	PADZZ		CMF55T10K0HMS	91637	RESISTOR, FIXED FILM.....	EA	2
8	33	PADZZ	5905-01-088-5937	4465D-1	11332	RESISTOR, THERMAL	EA	1
8	34	PADZZ	5962-01-007-6747	AD504M	24355	MICROCIRCUIT, LINEAR	EA	1
8	35	PADZZ	5962-00-167-6330	M38510/70101BGC	81349	MICROCIRCUIT, LINEAR	EA	1

SECTION IV

TM 11-5895-1090-24P

NATIONAL STOCK NUMBER AND PART NUMBER INDEX

STOCK NUMBER	FIG.	ITEM	STOCK NUMBER	FIG.	ITEM
5305-00-054-5636	4	2	5310-00-595-6211	3	3
5305-00-054-5638	3	6	5310-00-595-6211	4	12
5305-00-054-5638	7	4	5310-00-595-6211	5	15
5305-00-054-5643	3	12	5310-00-595-6211	7	15
5305-00-054-5643	4	8	5310-00-595-6761	3	8
5305-00-054-5643	7	10	5310-00-595-6761	4	4
5305-00-054-5644	1	15	5310-00-595-6761	7	6
5305-00-054-5647	1	55	5910-00-600-6889	6	3
5305-00-054-5647	3	1	5355-00-616-9604	1	115
5305-00-054-5647	4	10	5310-00-619-1148	1	13
5305-00-054-5648	1	40	5310-00-627-6128	1	96
5305-00-054-5649	7	13	5905-00-681-6462	8	19
5305-00-054-5650	1	35	5905-00-682-4101	8	21
5305-00-054-5653	1	124	5930-00-683-1626	1	112
5305-00-054-6654	1	37	5905-00-683-7720	8	20
5305-00-054-6654	7	18	5340-00-721-5315	1	42
5305-00-054-6656	2	12	5310-00-722-5998	2	11
5305-00-054-6669	1	86	5310-00-722-5998	7	19
5305-00-054-6669	2	20	6240-00-723-3378	1	105
5305-00-054-6670	1	58	5305-00-738-0624	2	25
5355-00-055-3497	1	119	5905-00-739-6693	8	16
5355-00-055-3497	2	39	5340-00-753-3456	1	25
5305-00-056-9961	1	79	5905-00-760-0327	6	9
5310-00-063-6716	1	90	5935-00-762-1495	1	6
5305-00-066-7328	1	36	5935-00-779-8294	6	6
5305-00-068-5276	3	23	5305-00-780-1131	2	27
5305-00-079-5835	1	82	5935-00-783-2071	8	13
5305-00-082-8440	1	103	5310-00-807-1465	1	108
5961-00-087-6047	5	3	5310-00-809-4058	1	92
5305-00-088-9666	1	26	5905-00-810-1055	8	15
5305-00-088-9670	1	48	5910-00-810-4849	8	8
5935-00-089-4440	1	69	5310-00-812-4292	1	97
5935-00-089-4858	5	5	5940-00-813-0698	1	44
5905-00-110-0388	6	15	5935-00-823-0673	1	78
5905-00-111-4734	2	14	5961-00-833-3043	6	17
5940-00-113-8184	1	93	5310-00-837-1381	2	32
5905-00-114-5343	6	14	5305-00-840-5938	1	83
5905-00-116-8569	5	9	5310-00-845-5030	1	45
5310-00-138-9806	2	40	5961-00-847-5246	6	18
5905-00-141-1183	6	10	5935-00-849-7189	1	67
5920-00-142-7439	8	14	5330-00-853-3975	2	24
5940-00-143-4771	1	99	5310-00-880-5978	1	24
6240-00-155-7836	1	113	5310-00-880-5978	2	17
5962-00-167-6330	8	35	5920-00-881-6584	1	132
5310-00-180-0277	1	120	5305-00-889-2991	1	65
5930-00-182-7474	1	116	5935-00-904-4896	1	54
6210-00-183-0576	1	106	5905-00-922-9755	8	30
5310-00-184-9161	1	76	5310-00-928-2690	3	7
5905-00-189-2468	5	6	5310-00-928-2690	4	3
5905-00-192-3479	5	7	5310-00-928-2690	7	5
5310-00-208-3786	1	32	5310-00-929-6395	1	30
5905-00-232-2946	6	13	5310-00-933-8118	1	33
5305-00-241-1076	2	5	5310-00-933-8118	3	2
5940-00-254-5216	1	126	5310-00-933-8118	7	14
5945-00-256-0669	5	4	5310-00-933-8119	1	59
5945-00-256-0669	6	5	5310-00-933-8119	2	33
5910-00-279-1864	6	1	5961-00-938-1135	6	4
5920-00-280-8344	1	101	5961-00-938-1135	8	10
6625-00-361-8530	4	1	5310-00-938-2013	3	11
6625-00-361-8530	7	2	5310-00-938-2013	4	7
5305-00-403-3465	2	34	5310-00-938-2013	7	9
5910-00-409-9879	6	2	5330-00-947-4271	1	85
5935-00-410-9251	2	15	5961-00-949-1432	6	7
6645-00-413-0461	1	34	5310-00-952-1872	1	23
6625-00-431-8999	8	5	5310-00-982-5000	1	70
5310-00-442-6911	1	98	5310-00-982-5003	2	10
5310-00-442-6913	4	11	5940-00-984-4538	1	46
5305-00-458-2832	1	29	5340-00-988-3210	1	28
5305-00-460-0673	1	80	5320-00-993-0679	5	14
5905-00-463-9990	6	11	5950-01-007-5762	8	12
5935-00-465-4378	1	51	5962-01-007-6747	8	34
5930-00-539-7013	1	111	5905-01-008-2882	8	18
5355-00-543-0789	1	118	5935-01-014-1444	1	5
5355-00-543-0789	2	38	5935-01-014-1445	1	22
5340-00-543-3931	1	27	5910-01-015-9236	8	9
5340-00-543-3931	2	35	5905-01-016-1038	6	8
5310-00-543-5933	1	100	5305-01-020-0176	1	68
5920-00-556-0144	1	102	5305-01-020-0178	2	16
5310-00-582-5965	1	91	5940-01-021-1844	1	41
5305-00-582-8843	3	20	5305-01-029-8874	1	49

SECTION IV

TM 11-5895-1090-24P

NATIONAL STOCK NUMBER AND PART NUMBER INDEX

STOCK NUMBER	FIG.	ITEM	STOCK NUMBER	FIG.	ITEM
5910-01-029-8906	1	127	5960-01-076-7037	1	8
5305-01-030-2255	1	72	5985-01-076-7043	7	12
5925-01-031-4861	1	107	5895-01-076-7058	1	39
5910-01-041-9159	5	2	5895-01-076-7063	1	57
5895-01-051-3044	1	64	5930-01-076-7075	1	117
5935-01-051-8341	1	52	5930-01-076-7076	1	129
5999-01-054-6449	6	20	5930-01-076-7077	1	131
5985-01-056-1037	3	9	6625-01-076-7116	1	133
5985-01-056-1037	4	5	5995-01-080-3623	1	11
5985-01-056-1037	7	7	5995-01-080-3624	1	2
5905-01-056-1046	1	130	5995-01-080-3625	1	3
5985-01-056-1090	4	13	5915-01-080-9999	7	17
5985-01-056-1091	3	4	5985-01-081-0020	3	16
5985-01-056-1091	4	15	5995-01-081-0021	2	2
5985-01-056-1091	7	16	5995-01-081-0022	2	1
5305-01-058-1232	8	2	5995-01-081-0023	2	4
5905-01-061-3871	6	12	5995-01-081-0024	2	3
5305-01-065-7119	1	95	5995-01-081-0025	2	8
5310-01-065-7120	1	75	5995-01-081-0026	7	3
5935-01-069-6794	1	50	5995-01-081-0027	1	9
6210-01-070-3873	1	114	5895-01-081-0056	1	12
5330-01-070-3986	1	128	5895-01-081-0057	1	10
5306-01-070-8068	1	84	5895-01-081-0058	1	1
5305-01-071-6364	1	62	5895-01-081-0087	1	61
5305-01-072-4419	2	23	5999-01-081-0100	5	13
5305-01-074-3352	2	36	5910-01-084-3516	5	1
5895-01-076-6945	2	13	5935-01-088-2849	8	11
5985-01-076-6946	2	6	5905-01-088-5937	8	33
5895-01-076-6947	2	19	5905-01-089-0613	8	31
5985-01-076-6948	3	15			

PART NUMBER	FSCM	FIG. NO.	ITEM NO.	PART NUMBER	FSCM	FIG. NO.	ITEM NO.
AD504M	24355	8	34	MS2109C0820L	96906	3	26
AN56504H1	88044	3	20	MS21318-19	96906	1	83
BT07A14-15P	09922	8	11	MS24523-30	96906	1	112
CK05BX472M	81349	8	9	MS24693-72	96906	1	17
CMF55T110KOHMS	91637	8	32	MS24693C27	96906	1	36
CMF55T1149.5KOHM	91637	8	26	MS24693C4	96906	1	79
CMF55T294KOHMS	91637	8	23	MS24693C48	96906	1	65
CMF55T2100KOHMS	91637	8	29	MS24693C50	96906	1	82
CMF55T2100OHMS	91637	8	22	MS24693C51	96906	1	26
CMF55T21000OHMS	91637	8	28	MS24693C53	96906	1	48
CMF55T214.2KOHMS	91637	8	25	MS24693C72	96906	2	27
CMF55T2200OHMS	91637	8	17	MS25036-101	96906	1	44
CMF55T24990OHMS	91637	8	27	MS25036-103	96906	1	99
CMF55T2665.3OHMS	91637	8	24	MS25036-150	96906	1	93
CMR06F102GODR	81349	1	127	MS25082C20	96906	2	40
FHL17G2	81349	1	132	MS25237-327	96906	1	113
FHN20G	81349	1	102	MS25281R2	96906	1	25
F02A250V1/2A	81349	1	101	MS25281R3	96906	1	27
JAN1N4148	81349	6	4	MS25281R3	96906	2	35
JAN1N4148	81349	8	10	MS25281R4	96906	1	28
JAN1N645	81349	5	3	MS25281R5	96906	1	42
JAN1N746A	81349	6	18	MS27183-10	96906	1	92
JAN1N757A	81349	6	17	MS3110E14-19S	96906	1	67
JAN2N2219A	81349	6	7	MS3110E16-8P	96906	1	78
LH88/2	81349	1	106	MS3116E14-15S	96906	8	13
MS15795-802	96906	3	8	MS3116F12-01S	96906	1	6
MS15795-802	96906	4	4	MS3116F14-15S	96906	1	54
MS15795-802	96906	7	6	MS3116F14-19P	96906	6	6
MS15795-803	96906	3	3	MS3212-1	96906	2	25
MS15795-803	96906	4	12	MS3212-13	96906	1	103
MS15795-803	96906	5	15	MS35333-73	96906	1	100
MS15795-803	96906	7	15	MS35333-76	96906	1	120
MS15795-805	96906	2	11	MS35333-80	96906	1	76
MS15795-805	96906	7	19	MS35335-35	96906	1	96
MS15795-807	96906	1	24	MS35338-134	96906	3	7
MS15795-807	96906	2	17	MS35338-134	96906	4	3
MS15795-808	96906	1	73	MS35338-134	96906	1	5
MS16535-163	96906	5	14	MS35338-135	96906	1	33
MS166244025	96906	3	19	MS35338-135	96906	3	2
MS16995-9	96906	3	23	MS35338-135	96906	7	14
MS17325-5	96906	1	34	MS35338-136	96906	1	30
MS21042-06	96906	1	108	MS35338-137	96906	1	59
MS21045-C04	96906	1	70	MS35338-137	96906	2	33
MS21045-C08	96906	1	23	MS35338-44	96906	1	91
MS21045C06	96906	2	10	MS35426-14	96906	1	90

PART NUMBER	FSCM	FIG. NO.	ITEM NO.	PART NUMBER	FSCM	FIG. NO.	ITEM NO.
MS35649-224	96906	3	11	RNR60C3012FM	81349	6	12
MS35649-224	96906	4	7	RNR60C5111FM	81349	6	8
MS35649-224	96906	7	9	RNR60C75R0FS	81349	6	9
MS51957-11	96906	1	15	RN55C1020F	81349	8	30
MS51957-13	96906	1	55	RN60C1000F	81349	8	15
MS51957-13	96906	3	1	SM-A-775612	80063	3	9
MS51957-13	96906	4	10	SM-A-775612	80063	4	5
MS51957-14	96906	1	40	SM-A-775612	80063	7	7
MS51957-15	96906	7	13	SM-A-775613	49671	4	13
MS51957-16	96906	1	35	SM-A-775715	49671	1	8
MS51957-19	96906	1	124	SM-A-776168-1	49671	2	28
MS51957-2	96906	4	2	SM-A-776168-7	49671	1	18
MS51957-30	96906	1	37	SM-A-776170-2	49671	4	1
MS51957-30	96906	7	18	SM-A-776170-2	49671	7	2
MS51957-32	96906	2	12	SM-A-776188-24	49671	1	16
MS51957-4	96906	3	6	SM-A-776957	49671	3	4
MS51957-4	96906	7	4	SM-A-776957	49671	4	15
MS51957-44	96906	1	86	SM-A-776957	49671	7	16
MS51957-44	96906	2	20	SM-A-776959	49671	1	130
MS51957-45	96906	1	58	SM-A-777751-1	49671	1	94
MS51957-9	96906	3	12	SM-A-916419	49671	1	20
MS51957-9	96906	4	8	SM-A-916419	49671	2	30
MS51957-9	96906	1	10	SM-A-916419	49671	7	22
MS77069-3	96906	1	126	SM-A-916427	49671	6	22
MS9048-035	96906	1	89	SM-A-916441-2	49671	1	114
MS91528-1N28	96906	1	118	SM-A-916470	49671	1	51
MS91528-1N2B	96906	2	38	SM-A-916471	49671	1	111
MS91528-1P2B	96906	1	115	SM-A-916472	49671	1	129
M15098/11-002	81349	1	105	SM-A-916473	49671	1	131
M21097/4-01	81349	1	69	SM-A-916478	49671	2	13
M21097/5-01	81349	5	5	SM-A-934947-1	49671	7	12
M24308/1-1	81349	1	51	SM-A-934961-1	49671	3	28
M24308/20-6	81349	1	52	SM-A-934965	49671	1	53
M24308/25-1	81349	1	50	SM-A-934966-1	49671	1	116
M24308/3-1	81349	2	15	SM-A-934967	80063	1	119
M38510/10101BGC	81349	8	35	SM-A-934967	80063	2	39
M38527/1-21B1	81349	6	21	SM-A-934976	49671	1	123
M38527/3-01D	81349	6	20	SM-A-935195-2	49671	2	31
M39003/01-2245	81349	6	1	SM-A-935198	49671	2	6
M39003/01-5031	81349	6	2	SM-A-935200	49671	1	39
M39006/09-8279	81349	5	1	SM-A-935236-2	80063	1	41
M39012/55-4026	81349	1	5	SM-A-935256	80063	1	17
M39012/56-3028	81349	1	22	SM-A-935259-1	49671	1	133
M39014/02-1230	81349	6	3	SM-A-935259-2	49671	1	125
M39014/02-1240	81349	5	2	SM-A-935269	80063	3	16
M39019/01-218	81349	1	107	SM-A-935270	49671	3	15
M5423/02-01	81349	1	111	SM-A-935804-1	49671	3	13
M5757/70-002	81349	5	4	SM-A-935804-1	49671	4	9
M5757/70-002	81349	6	5	SM-A-935804-2	49671	7	11
NAS1291C08M	80205	1	45	SM-A-935828-1	49671	5	10
NAS598C06Y	80205	2	24	SM-A-935843-1	49671	3	10
NAS1598C3Y	80205	1	85	SM-A-935843-1	49671	4	6
NAS1635-04-10	80205	1	68	SM-A-935843-1	49671	7	8
NAS1635-04-5	80205	2	5	SM-A-935843-2	49671	3	5
NAS1635-06-6	80205	1	29	SM-A-936511	49671	3	14
NAS1635-08-10	80205	2	34	SM-A-937086	49671	6	16
NAS1635-08-14	80205	1	49	SM-A-937257	49671	7	1
NAS1635-08-7	80205	2	16	SM-B-447176-4	49671	6	23
NAS1635-3-10	80205	1	72	SM-B-447366-2	49671	6	19
NAS1635-3-7	80205	1	80	SM-B-775541	49671	5	11
NAS1640-10	80205	1	98	SM-B-775546	49671	5	12
NAS1640-4	80205	4	11	SM-B-775557	49671	1	95
NAS671C10	80205	1	97	SM-B-775562-1	49671	2	36
NAS671C4	80205	1	32	SM-B-775562-3	49671	2	23
NAS671C8	80205	2	32	SM-B-775562-5	49671	1	62
P1C#N3-1	00141	3	18	SM-B-777826	49671	1	77
RCR07G101JS	81349	6	10	SM-B-777831	49671	1	75
RCR07G104JM	81349	6	15	SM-B-889952	49671	1	74
RCR07G182JS	81349	6	14	SM-B-889966	80063	1	128
RCR07G332KM	81349	6	11	SM-B-935303	49671	2	41
RCR20G470JS	81349	2	14	SM-B-935304	49671	2	42
RCR20G821JS	81349	5	9	SM-B-935305	49671	3	22
RCR20G822JS	81349	4	17	SM-B-935306	49671	3	21
RC07GF102J	81349	8	19	SM-B-935322-1	49671	1	121
RC07GF510J	81349	8	20	SM-B-935322-2	49671	1	109
RC07GF752J	81349	8	21	SM-B-935334	49671	1	11
RJR24CP503M	81349	5	8	SM-B-935335	49671	1	122
RNC60K3482FS	81349	5	6	SM-B-935347	49671	2	26
RNC60K9091FS	81349	5	7	SM-C-775486-6	49671	1	84
RNR60C1000FS	81349	6	13	SM-C-890627-19	49671	1	47

PART NUMBER	FSCM	FIG. NO.	ITEM NO.	PART NUMBER	FSCM	FIG. NO.	ITEM NO.
SM-C-890816-3	49671	1	43	SM-D-935053	49671	2	19
SM-C-935485	49671	7	20	SM-D-935081	80063	1	10
SM-C-935928	49671	1	110	SM-D-935082	80063	1	1
SM-C-935930	49671	1	60	SM-D-935507	80063	1	61
SM-C-935931	49671	1	71	SM-D-935577	49671	2	29
SM-C-935932	49671	1	66	SM-D-935578	49671	2	18
SM-C-935939	49671	3	24	SM-D-935579	49671	3	17
SM-C-935962	80063	7	3	SM-D-935579-1	49671	3	29
SM-C-935963	49671	4	14	SM-D-935579-2	49671	3	27
SM-C-935973	80063	2	1	SM-D-935579-5	49671	3	25
SM-C-935974	80063	2	2	SM-D-935582	49671	4	16
SM-C-935979	80063	2	4	SM-D-935586	49671	7	21
SM-C-935980	80063	2	3	SM-D-935590	80063	5	13
SM-C-935985	49671	2	37	SM-D-936315	49671	1	38
SM-C-935986	49671	2	22	SM-D-936320	49671	2	21
SM-C-936400	49671	1	104	SM-D-936321	49671	1	87
SM-C-936420	49671	1	31	SM-F-935052	80063	1	12
SM-C-936460	49671	1	63	SM-F-935723	49671	1	19
SM-C-936468	49671	1	14	TG-S10	56289	8	8
SM-C-936471	80063	1	13	TL-2A	11332	8	5
SM-C-936472	80063	1	3	UG-536B/U	81349	1	21
SM-C-936473	80063	1	2	2N2222A	81349	8	14
SM-C-936482	49671	2	9	3017F	11332	8	3
SM-C-936483	80063	2	8	3155F-1	11332	8	4
SM-C-936484	49671	2	7	3155F-3	11332	8	6
SM-C-936714	80063	1	9	33620	11332	8	12
SM-C-936721	49611	1	56	38TB9	81349	1	46
SM-C-936725-1	49671	1	1	3928G	11332	8	1
SM-C-936725-2	49671	1	4	4465D-1	11332	8	33
SM-C-936769	49671	1	134	76-70-10K	58022	8	31
SM-D-775384	49671	1	64	7936A-8	11332	8	2
SM-D-777131-12	49671	1	81	812150-651-104M	72982	8	1
SM-D-777132-12	49671	1	88	84-3-8-101	02111	8	16
SM-D-777766	49671	6	24	850-208-10K	77630	8	18

RECOMMENDED CHANGES TO EQUIPMENT TECHNICAL PUBLICATIONS



THEN... JOT DOWN THE DOPE ABOUT IT ON THIS FORM, CAREFULLY TEAR IT OUT, FOLD IT AND DROP IT IN THE MAIL!

SOMETHING WRONG WITH THIS PUBLICATION?

FROM: (PRINT YOUR UNIT'S COMPLETE ADDRESS)

DATE SENT

PUBLICATION NUMBER

PUBLICATION DATE

PUBLICATION TITLE

BE EXACT... PIN-POINT WHERE IT IS

PAGE NO.

PARA-GRAPH

FIGURE NO.

TABLE NO.

IN THIS SPACE TELL WHAT IS WRONG AND WHAT SHOULD BE DONE ABOUT IT:

TEAR ALONG PERFORATED LINE

PRINTED NAME, GRADE OR TITLE, AND TELEPHONE NUMBER

SIGN HERE:

DA FORM 2028-2
1 JUL 79

PREVIOUS EDITIONS
• ARE OBSOLETE.

P.S.—IF YOUR OUTFIT WANTS TO KNOW ABOUT YOUR RECOMMENDATION MAKE A CARBON COPY OF THIS AND GIVE IT TO YOUR HEADQUARTERS.

